

4-WAY HAND PALLET TRUCKS

OPERATION INSTRUCTIONS
SPARE PARTS LIST

FK2300 / 1500 4-Way

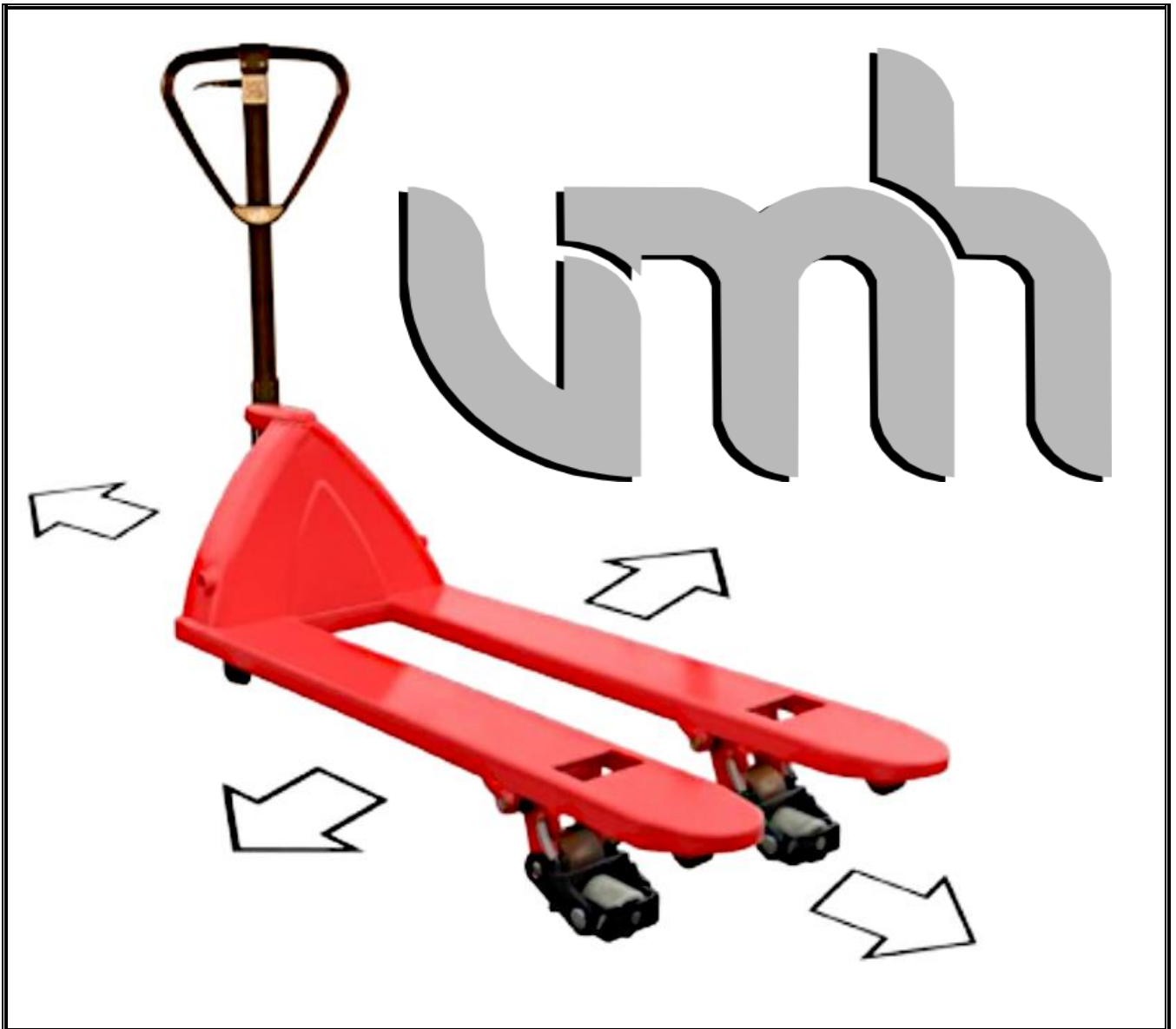

EC DECLARATION OF CONFORMITY

All information you need for the use and maintenance of your low loader can be found in this operating manual. Before switching on the car, read the owner's manual carefully and follow the instructions contained therein. They help you prevent accidents and maintain the warranty conditions and therefore their validity.

The pallet truck described in this manual is manufactured using the most modern technological processes. During construction, all applicable safety standards and regulations were observed.

VMH - Material Handling s.r.o. Sabinovská 53, 082 21 Veľký Šariš, SLOVAKIA



Tel.: 00421 51 7495160
Fax.: 00421 51 7495160
E-mail: vmh@vmh.sk
Web: www.vmh.sk



The declaration of conformity indicates that a forklift truck complies with the relevant directives at the time it is placed on the market:

- * **CE: European Union (EU)**
- * **UKCA: United Kingdom of Great Britain (UK)**

The Declaration of Conformity is issued for the EU and United Kingdom (UK) markets.

★ ★ ★ EC Declaration of Conformity ★ ★ ★	
to EC Machinery Directive: 2006/42/EC	
Producer: VMH–Material Handling s.r.o., Sabinovská 53, SK-082 21 Veľký Šariš, Slovakia Reg. Nr.: 45 452 237	
We, represented by the undersigned, here by declare that the following machinery:	
4-WAY HAND PALLET TRUCKS	
FK2300/1500 4-Way with capacity 2300/1500 kg (also, with additional components and derivations)	
conforms to the following relevant provisions / directives:	
EC Machinery Directive 2006/42/EC	
Further standards / specifications / documents used in the form of	
Harmonised Standards:	EN ISO 12100:2010
	ES ISO 3691-5:2015+A1:2020
Veľký Šariš, Slovakia 19.01.2025	Vladimír Havrila

IMPORTANT:

Unauthorized interventions or changes to the structure of the pallet truck can lead to injuries and a general safety hazard in the workplace. Such an intervention in the structure will result in the declaration of conformity becoming invalid.

INSTRUCTIONS FOR ASSEMBLING THE PALLET TRUCK

ASSEMBLING THE CONTROL PART

- * Check that the piston is pushed to the lower position.
- * Insert the hydraulic piston (1) in an inclined position into the "head" of the structure (3). Rotate the plate (6) so that the holes are facing/pointing towards the arm (5). Hold the reins with your hands and feet, push the hydraulic system to slide the plate (6) over the arm (5).
- * Raise both slides so that the holes in the plate (6) are parallel to the holes in the arm (5).
- * Attach the plate (6) to the arm (5) using the plate pin (4).
- * Secure the plate pin (4) with a flexible pin (Ø 5mm) (7).

Tools: Hammer,

IMPORTANT:

Before starting, pump the hydraulic system several times (control lever up) to bleed the hydraulic system.

Accessory:

- 2x plate pin
- 2x flexible pin (Ø 5mm)

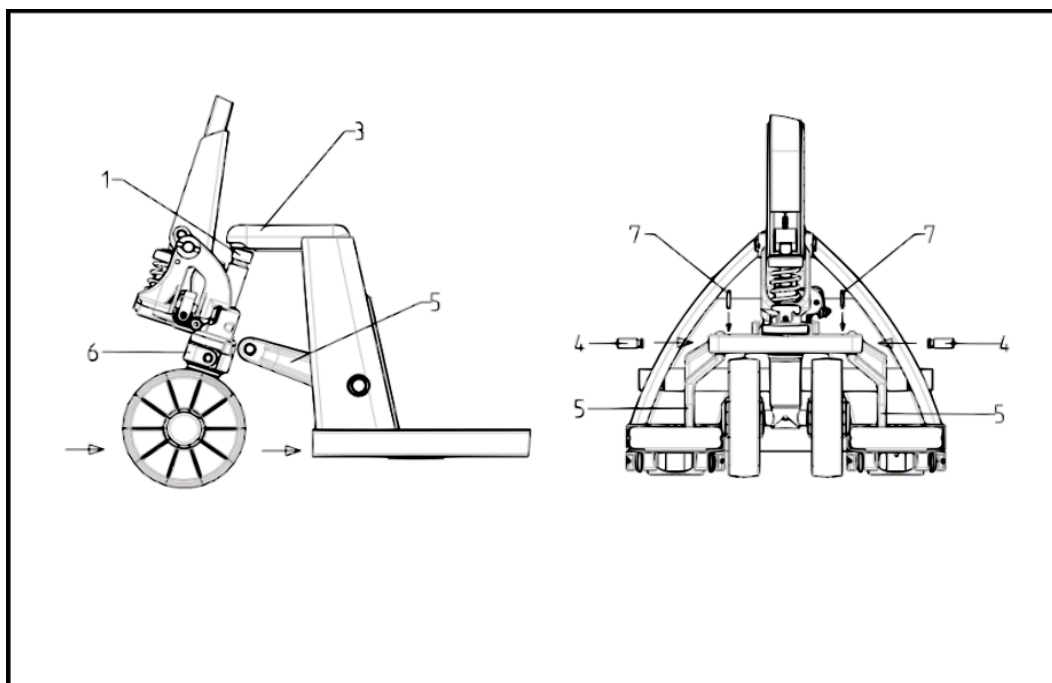

The department may not modify the instructions for use.

The descriptions and illustrations in the operating instructions and the spare parts list are not binding. For further development or for technical reasons, we reserve the right, at any time, to make any modifications we deem appropriate to the assembly sets, individual parts and accessories, whilst maintaining the essential characteristics of the type of stroller described below.

CONTENTS

Instructions for assembling the pallet truck	Page 1
Contents	Page 2
Description and drawing documentation	Page 3
Warning before commissioning	Page 3
Notice to user	Page 3
Load regulations	Page 3
Security settings	Page 4
Safety warnings	Page 4
Guarantee	Page 4
Termination of warranty	Page 4
Checking the oil level	Page 5
Adjustments	Page 5
Replacing the valve cartridge h 016	Page 5
Filling oil and ventilating	Page 5
Please note!	Page 5
Instructions on eliminating faults	Page 6
Assembly drawings	Page 7
Steering assembly, explosive drawing	Page 8
Steering assembly, parts (L 001 – L 027)	Page 9
Chassis, explosive drawing	Page 10
Chassis, parts (F 001 – F 020)	Page 11
Load wheels 4-Way HPTs, drawing	Page 12
Load wheels 4-Way HPTs, parts (001 – 010)	Page 12
Hydraulics, explosive drawing	Page 13
Hydraulics, parts (H 001 – H 024)	Page 14
Wheel- and parking brake, explosive drawing	Page 15
Wheel- and parking brake, parts (B 001 – B 005)	Page 16

DESCRIPTION AND DRAWING DOCUMENTATION

WARNING BEFORE COMMISSIONING

The hand pallet truck is carefully inspected before it leaves the factory. To ensure that no damage has occurred during transport, check that the trolley is not damaged and that it is functional. Indicate the damage caused by the transport in the copy of the transport note. Submit damage reports to the freight forwarder within 48 hours. Damaged trucks must not be put into operation.

NOTICE TO USER

On the drawbar of the hand pallet truck there is a manual lever for raising and lowering the truck, which you can put in three positions:

- Raise – lever in the down position
- Drive position – lever in centre position
- Lower – lever in the upper position

When towing a hand pallet truck, put the hand lever in the neutral position. This makes it easier to move the drawbar and the pump area in the hydraulics is pressure-free. This saves hydraulic seals and individual parts of the valve. This will give you a longer lifespan.

The hand pallet truck is largely maintenance-free, but the oil level needs to be checked and topped up if necessary. Individual bearings and pins have long-term lubrication.

We recommend that you lubricate all lubrication points marked (→) in the user manual with a long-term lubricant in monthly cycles or with each thorough cleaning, depending on the use of the wheelchair.

LOAD REGULATIONS

This special 4-Way HPT can move in all four directions.

Easy handling across narrow spaces.

Stability of lateral movement provided by locking pin.

Capacity for traverse movement – **1500 kg**

Lift for lateral movement – **170 mm**

The hand pallet truck is intended for the horizontal transport of heavy loads on a flat and reinforced surface.

Transported goods must be evenly stored on pallets or similar containers.

The maximum permissible load is indicated on the type plate and sticker with the permissible load, which are located on the hand pallet truck.

If the skids are loaded on one side, there is a danger that the skids will deform or that the load will slip.

Do not under any circumstances lift or shift the load at the end of the skids, as you may damage the truck.

To protect the wheels and the steering part, make sure not to use the cart on a surface with large unevenness.

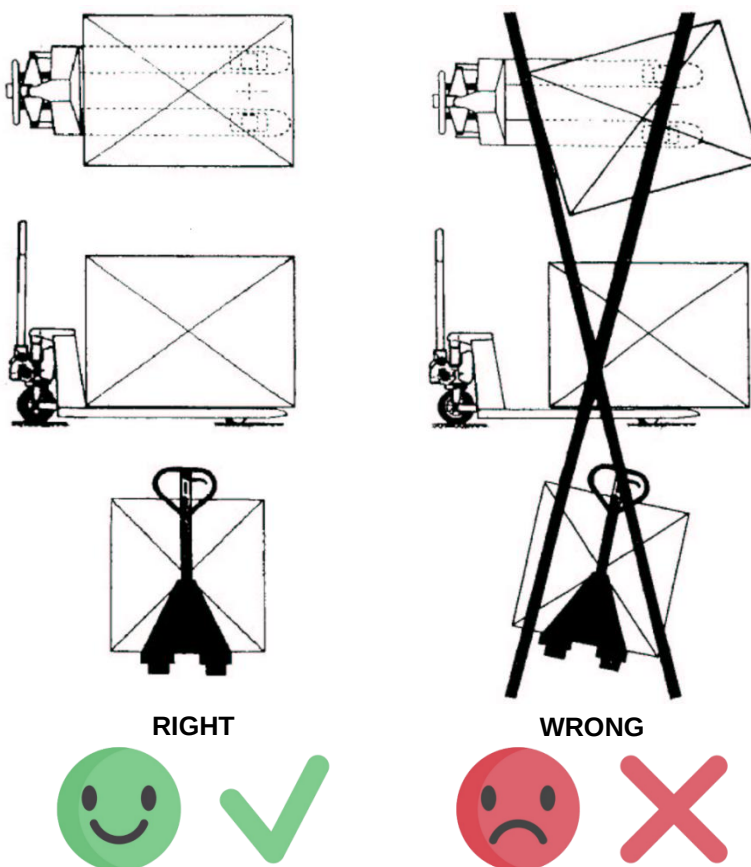

SECURITY SETTINGS

The hand pallet truck is equipped from the factory with a safety valve that is firmly set. This valve admits a maximum load of up to +5% of the rated load. The valve is secured with a safety screw so that the user cannot adjust it. In order to exclude the possibility of damage to the transported goods, it is necessary to pay attention to the even distribution of the load. If the load is unevenly distributed, the safety valve is ineffective.

When transporting goods on an inclined surface, it is necessary to ensure that the goods do not slip off the pallet truck, or one more person is required during handling. Therefore, it is necessary to use a hand pallet truck on an inclined surface up to approx. 6% only with service and parking brake.

Manipulation during an ascent or descent of more than 6% is fundamentally inadmissible. It is not possible to ensure safe transport by changing the center of gravity.

SAFETY WARNINGS

Transporting with high loads, e.g. machines, changes the centre of gravity of the load so unfavourably that the complete hand pallet truck including the load, goes out of control and may overturn on a curve. Loading, e.g. onto a truck or mobile loading ramps, should be regarded in particular as likely occasions for accidents. During such activities the hand pallet truck is to be secured with particular care.

Conveying persons or using the hand pallet truck as a form of roller skate is not permissible. Foodstuffs are only to be transported in packed form. Direct contact with the hand pallet truck is to be avoided.

The accident prevention regulations for industrial trucks and the safety regulations and accident prevention regulations applicable to the user are also to be complied with.

GUARANTEE

The guarantee includes material and assembly defects on parts which have proved to be incorrect or inadequate for normal use when tested by the manufacturer and which are returned to the manufacturer free of charge within the guaranteed period of 12 months.

The guarantee expires if inappropriate or unadvised repair is undertaken by the user.

TERMINATION OF WARRANTY

The manufacturer does not accept warranty for damage to persons and objects caused by deficiencies and errors in the delivered low-lift truck or due to improper use of the truck. The manufacturer also assumes no liability for lost profits, downtime, losses or similar indirect losses incurred by the buyer. Compensation for damage to third parties, of any type, is excluded.

CHECKING THE OIL LEVEL

To be carried out at least once a year. Lower the hand pallet truck and tank cap H 024.

The oil in the oil reservoir must reach 15 mm the lower edge of the sealing opening when the hydraulics are lowered. Top up, if necessary.

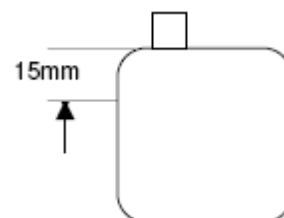

Types of oil:	
According for DIN 51524 (German Industry Standards)	HLP 46: (Standard, corrosion-proof and wet storage versions)
	HV 15: (For use cold storage houses)
	HV 32: (Quick lift hydraulic and underground conveyor systems)

Raise and lower the hand pallet truck several times, then check the oil level again.

Screw on H 024 tank cap.

ADJUSTMENTS

Move the lowering lever into the drive position.

Screw in hexagon nut H 020 and setscrew H 019 until the lifting piston remains stationary despite pumping at the drawbar.

Tighten hexagon nut H 020. The setscrew H 019 must not turn at the same time.

REPLACING THE VALVE CARTRIDGE H 016

Pump up hand pallet truck to the half-way position. Lift frame out of lifting piston rod, fold steering mechanism forwards, move hand pallet truck into the side position. Remove dowel pin H 018 on the hydraulics, fold lowering lever H 017 to one side, unscrew valve cartridge H 016 until the thread is free; press out the valve cartridge with a short firm blow on the lifting piston H 001.

Assemble the hand pallet truck in the reverse sequence after cleaning or replacing the valve cartridge.

FILLING OIL AND VENTILATING

When refilling the oil, make sure to bleed the hydraulics afterwards.

1. To ventilate the hydraulic, remove piston
2. Pour the oil (220 ml)
3. Insert piston again
4. Close tank and press piston down
5. Open tank again and pump until the piston is at half height
6. Repeat the procedure from point 4 again

PLEASE NOTE!

The following data must always be specified to ensure correct processing of your spare parts order:

- a) Truck type (load capacity)
- b) Series-No. of the truck
- c) Order No. of the spare part
- d) Year of construction

Instructions on eliminating faults			
Term	Fault	Cause	Remedy
1	Lifting piston only extends partially	Shortage foil	Refer to page 5 for checking oil level, top up oil
2	Lifting piston does not extend under load	Shortage of oil Adjust valve cartridge H 016 again Valve cartridge H 016 contaminated	Refer to item 1 Refer to Adjustment Instructions, page 5 Clean or replace valve cartridge
3	Hand pallet truck lowers under load	Valve cartridge H 016 contaminated Valve cartridge H 016 defective Lip seal H 003 defective	Refer to item 2 Replace control valve H 016 Replace lip seal
4	Lifting piston falls back into the limit position with every pump stroke	Valve cartridge H 016 does not operate Valve cartridge H 016 contaminated or defective	Check setting, refer to page 5 Refer to item 3
5	Specified load is not reached	Pressure-limiting valve H 015 defective	Replace pressure-limiting valve
6	Hand pallet truck does not lower	Valve cartridge H 016 blocked Chassis mechanism locked up	Check and make functional lowering mechanism from handle lowering linkage to control valve H 016. Remove foreign bodies, make functional
7	Hand pallet truck can be lowered too quickly or too slowly	Valve cartridge H 016 contaminated Choke ring defective	Clean control valve H 016 Replace control valve
8	Empty pumping of hydraulics	Air in hydraulic system	See Page 5. Fill oil and ventilate. Point 5 – 6.
9	Leakage at lifting piston	Wiper defective	Replace wiper H 002, ensure there are no foreign bodies in the sealing grooves. Only install lifting piston if surface is without defects
10	Leakage at pump piston	Wiper defective	Replace wiper H 005 and lip seal H 006. When installing, check piston is not damaged.

ASSEMBLY DRAWINGS:

Model: FK 2300/1500 4-Way **Weight:** 80 kg

Fork length: 810 mm, 910 mm, 1000 mm, 1150 mm, 1220 mm, 1500 mm, 1800 mm, 2000 mm, 2300 mm and special lengths.

Fig.-No. L 001 – L 027 : Steering assembly

Fig.-No. F 001 – F 020 : Chassis

Fig.-No. H 001 – H 024 : Hydraulics

Fig.-No. B 001 – B 005 : Wheel- and parking brake

Fig.-No. 001 – 010 : Load wheels 4-Way HPTs

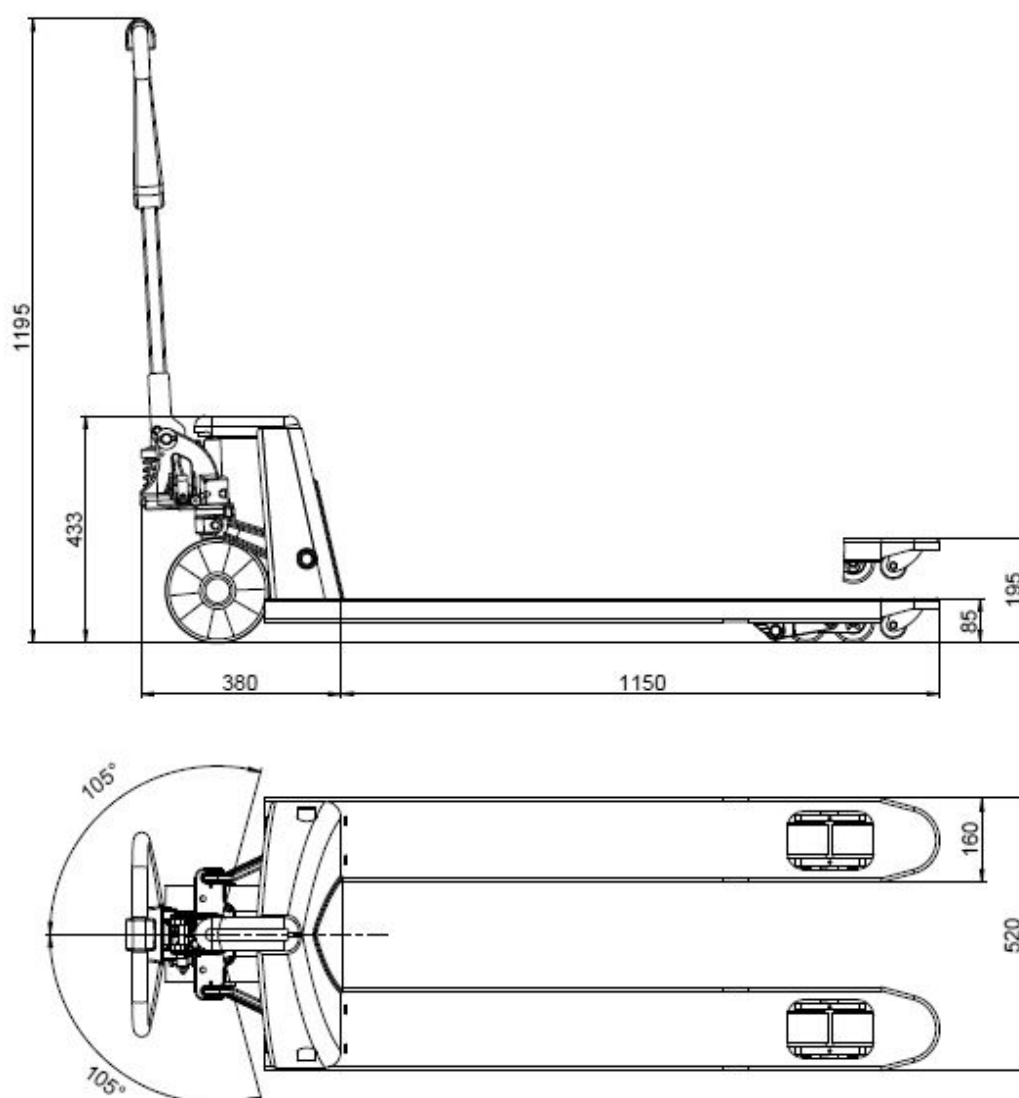

STEERING ASSEMBLY, EXPLOSIVE DRAWING

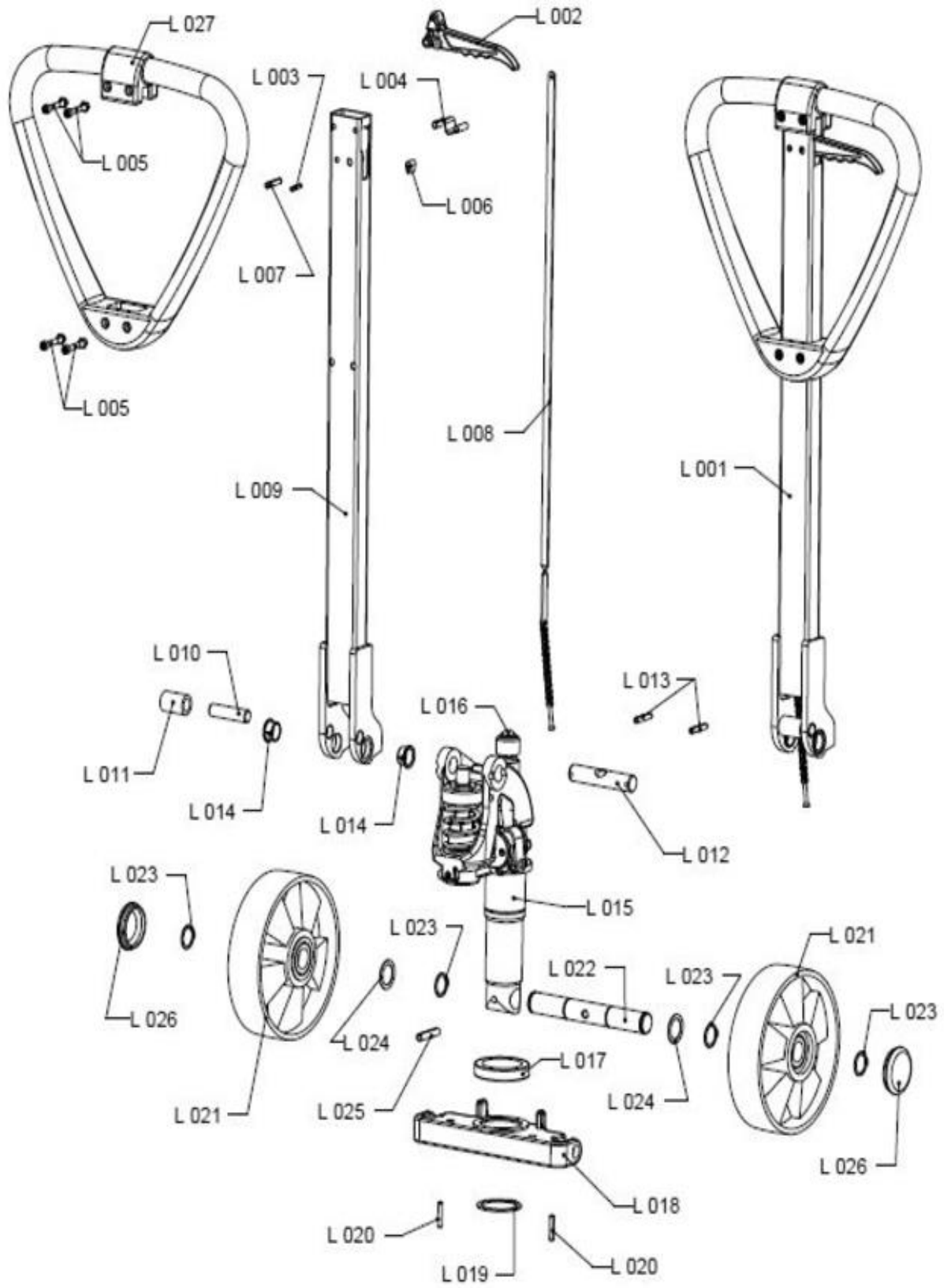

Steering assembly:

Fig. No.:	Order No.:	Designation:
L 001	G 63 000 031	Tiller handle, complete
	G 63 100 031	Tiller handle, complete, corrosion-protected
L 002	G 23 000 100	Lowering lever, complete
L 003	G 13 000 995	Tension pin-handle
	G 13 100 995	Tension pin-handle, corrosion-protected
L 004	G 63 000 183	Spring for lowering lever
L 005	G 63 000 182	Bolt and nut
	G 63 100 182	Bolt nut, corrosion-protected
L 006	G 11 000 185	Stip-Rubber
L 007	G 13 000 996	Tension pin – lowering linkage
	G 13 100 996	Tension pin – lowering linkage, corrosion-protected
L 008	G 63 000 170	Lowering linkage
	G 63 100 170	Lowering linkage, corrosion-protected
	G 63 200 170	Lowering linkage, stainless steel
L 009	G 63 000 131	Tiller body
	G 63 100 131	Tiller body, corrosion-protected
L 010	G 13 000 280	Pulley pin
	G 13 100 280	Pulley pin, corrosion-protected
L 011	G 13 000 290	Pulley
	G 13 100 290	Pulley, corrosion-protected
L 012	G 23 000 180	Pivot pin
	G 23 100 180	Pivot pin, corrosion protected
L 013	G 11 000 992	Tension pin – Pivot pin
	G 11 100 992	Tension pin – Pivot pin, corrosion-protected
L 014	G 33 000 178	Bush
L 015	G 63 111 220	Hydraulic – unit complete for 4-Way HPTs
L 016	G 13 010 880	Ball for lifting piston
L 017	G 13 000 240	Deep groove ball thrust bearing
	G 13 100 240	Deep groove ball thrust bearing, corrosion-protected
L 018	G 63 111 255	Pressure plate for 4-Way HPTs
L 019	G 13 000 981	Circlip ring – hydraulic shank
	G 13 100 981	Circlip ring – hydraulic shank, corrosion-protected
L 020	G 11 000 991	Tension pin for pressure plate
	G 11 100 991	Tension pin for pressure plate, corrosion-protected
L 021	G 11 000 500	Steer wheel rubber
	G 13 100 360	Steer wheel rubber, splash-proof bearings
	G 13 000 425	Steer wheel rubber, anti-static
	G 11 000 428	Steer wheel rubber, wear-resistant
	G 11 000 380	Steer wheel vulkollan
	G 11 000 415	Steer wheel polyurethane with steel core
	G 11 100 415	Steer wheel polyurethane with steel core, corrosion-protected
L 022	G 11 000 390	Steer wheel nylon
	G 13 100 390	Steer wheel nylon, splash-proof bearings
	G 11 000 420	Steer wheel steel
	G 63 000 330	Steer wheel shaft
	G 11 100 330	Steer wheel shaft, corrosion-protected
L 023	G 11 000 982	Circlip ring for steering roller shaft
	G 11 100 982	Circlip ring for steering roller shaft, corrosion-protected
L 024	G 11 000 350	Shim, steer wheel
	G 11 100 350	Shim, steer wheel, corrosion-protected
L 025	G 13 000 994	Tension pin for steering wheel shaft
	G 13 100 994	Tension pin for steering wheel shaft, corrosion-protected
L 026	G 11 000 440	Wheel cap, rubber
L 027	G 63 010 132	Handle

CHASSIS, EXPLOSIVE DRAWING

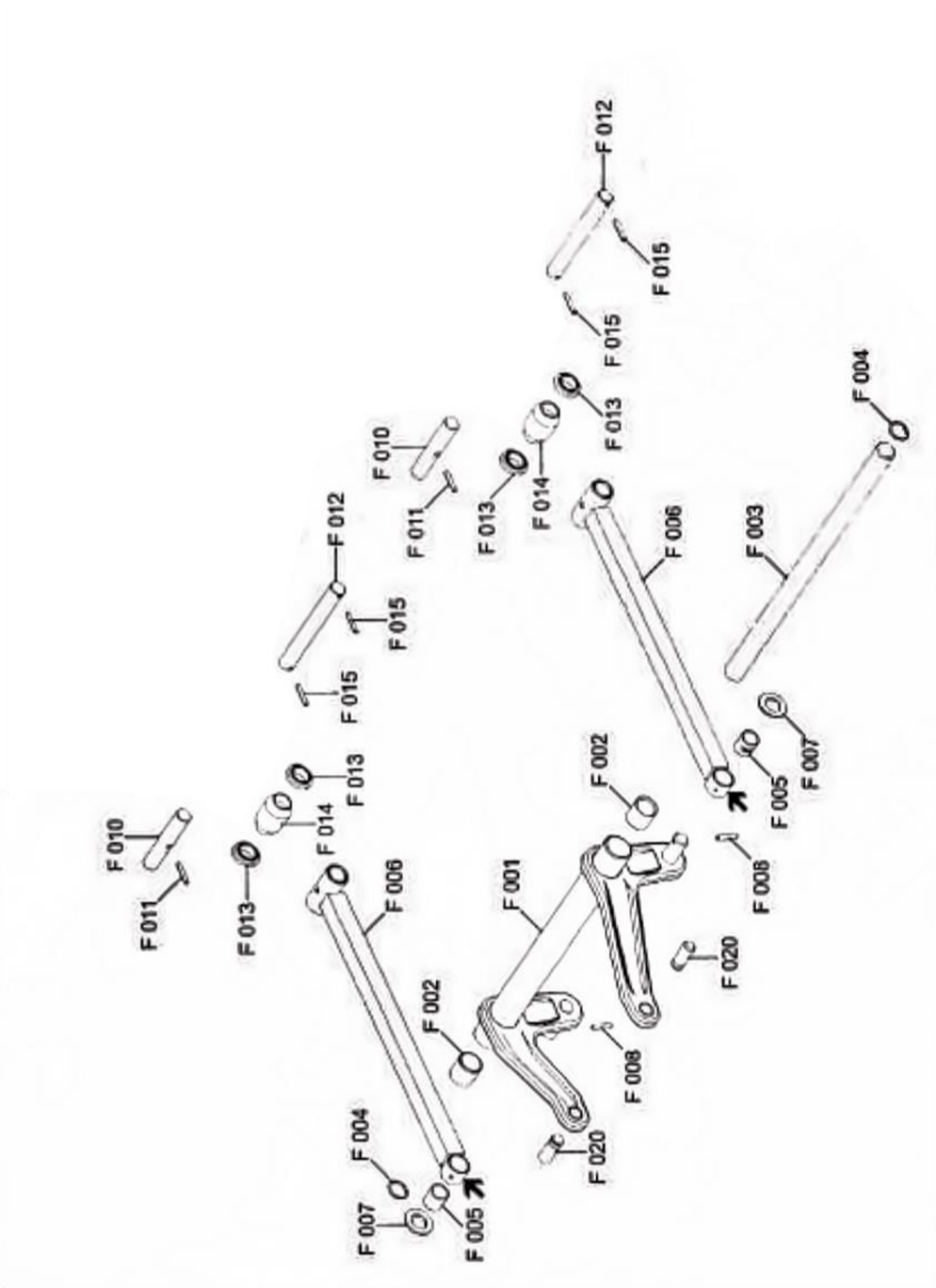

Chassis:

Fig. No.:	Order No.:	Designation:
F 001	G 63 012 300	Lift lever complete, for equipment width 450 mm,
	G 63 112 300	Lift lever complete, for equipment width 450 mm, corrosion protected
	G 63 014 300	Lift lever complete, for equipment width 520 mm,
	G 63 114 300	Lift lever complete, for equipment width 520 mm, corrosion-protected
	G 63 011 300	Lift lever complete, for equipment width 680 mm,
	G 63 111 300	Lift lever complete, for equipment width 680 mm, corrosion protected
F 002	G 63 010 315	Bush
F 003	G 63 012 320	Shaft for equipment width 450 mm, Ø25mm
	G 63 112 320	Shaft for equipment width 450 mm, Ø25 mm, corrosion-protected
	G 63 014 320	Shaft for equipment width 520 mm, Ø25 mm
	G 63 114 320	Shaft for equipment width 520 mm, Ø25mm, corrosion-protected
	G 63 011 320	Shaft for equipment width 680 mm, Ø25mm
	G 63 111 320	Shaft for equipment width 680 mm, Ø25mm, corrosion-protected
F 004	G 19 000 725	Circlip ring for shaft for equipment
no img.	G 11 100 991	Tension pin for shaft for equipment
F 005	G 11 010 420	Bush for eye front
F 006	G 11 010 440	Tie bar, complete for fork length 810 mm
	G 11 110 440	Tie bar, complete for fork length 810 mm, corrosion-protected
	G 11 010 445	Tie bar, complete for fork length 910 mm
	G 11 110 445	Tie bar, complete for fork length 910 mm, corrosion-protected
	G 11 010 450	Tie bar, complete for fork length 1000 mm
	G 11 110 450	Tie bar, complete for fork length 1000 mm, corrosion-protected
	G 11 010 460	Tie bar, complete for fork length 1150 mm
	G 11 110 460	Tie bar, complete for fork length 1150 mm, corrosion-protected
	G 11 010 470	Tie bar, complete for fork length 1220 mm
	G 11 110 470	Tie bar, complete for fork length 1220 mm, corrosion-protected
	G 11 010 480	Tie bar, complete for fork length 1500 mm
	G 11 110 480	Tie bar, complete for fork length 1500 mm, corrosion-protected
	G 11 010 490	Tie bar, complete for fork length 1800 mm
	G 11 110 490	Tie bar, complete for fork length 1800 mm, corrosion-protected
F 007	G 11 010 550	Shim
	G 11 110 550	Shim, corrosion-protected
F 008	G 11 000 991	Tension pin for tie bar
	G 11 100 991	Tension pin for tie bar, corrosion-protected
F 010	G 11 011 530	Shaft for tie bar for 4-Way HPTs
F 011	G 11 000 991	Tension pin for tie bar
	G 11 100 991	Tension pin for tie bar, corrosion-protected
F 012	G 11 011 540	Shaft for wheel fork for 4-Way HPTs
F 013	G 11 110 660	Intermediate roller for 4-Way HPTs
F 014	G 13 010 665	Extending roller
F 015	G 11 000 991	Tension pin for wheel fork
	G 11 100 991	Tension pin for wheel fork, corrosion-protected
F 020	G 13 010 890	Arm pin
	G 13 110 890	Arm pin, corrosion-protected

LOAD WHEELS 4-WAY HPTS, DRAWING

Fig. No.: 000

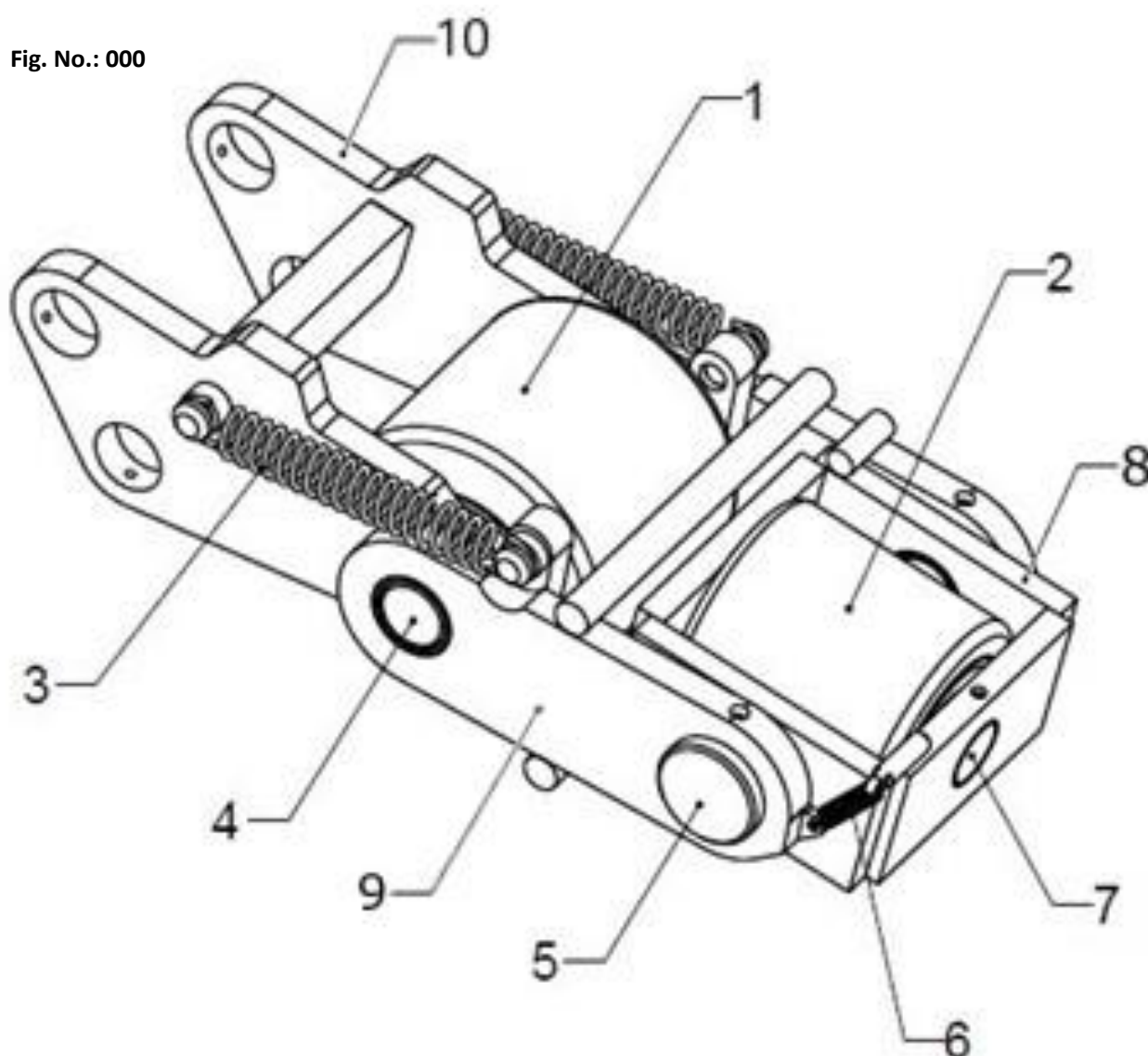

Load wheels 4-Way HPTs		
Fig. No.:	Order No.:	Designation:
000	G 11 020 520	Load wheels unit complete for 4-Way HPTs
001	G 11 010 740	Tandem load wheel, polyurethane with steel core
002	G 11 010 701	Cross wheel, nylon
003	G 11 000 998	Spring
004	G 11 010 560	Tandem wheel pin
005	G 11 111 455	Cross wheel cage pin
006	G 11 010 652	Spring
007	G 11 010 652	Cross wheel pin
008	G 11 111 540	Cross wheel cage
009	G 11 111 530	Arm
010	G 11 111 520	Wheel fork

HYDRAULICS, EXPLOSIVE DRAWING

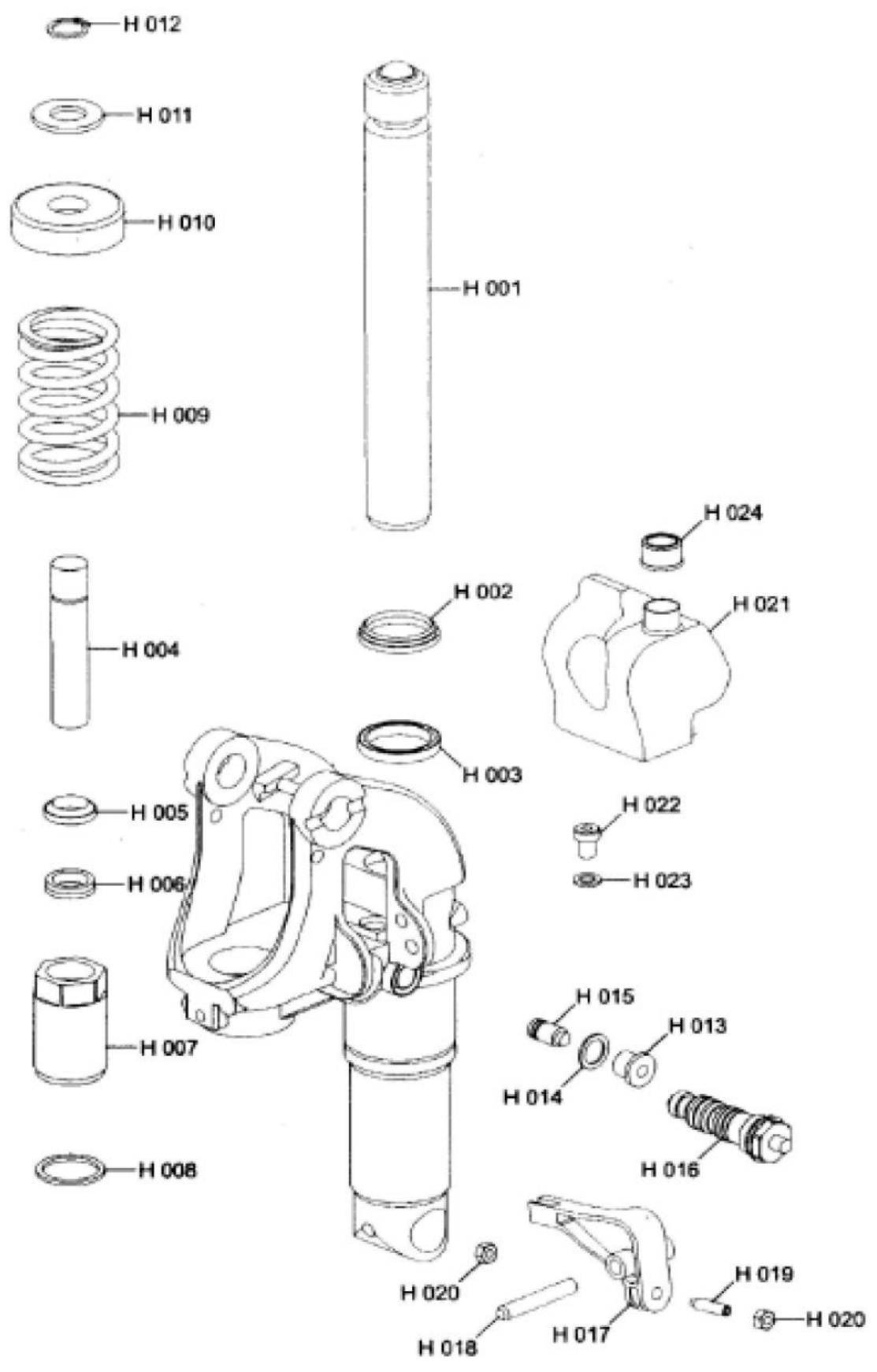

Hydraulics:

Fig. No.:	Order No.:	Designation:
H 001	G 63 020 010	Lifting piston
H 002	G 63 020 120	Wiper seal
H 003	G 03 020 030	Grooved ring
H 004	G 63 020 190	Pump plunger
H 005	G 03 020 201	Wiper seal
H 006	G 03 020 203	Grooved ring
H 007	G 63 020 160	Screwed cylinder, standard
H 008	G 63 020 162	Sealing ring
H 009	G 63 020 170	Compression spring – pump plunger
H 010	G 13 020 150	Protective sleeve
H 011	G 63 020 260	Shim
H 012	G 63 020 250	Snap ring
H 013	G 03 020 380	Screw plug
H 014	G 03 020 390	Sealing ring
H 015	G 63 020 320	Pressure control valve
H 016	G 03 020 383	Valve cartridge
H 017	G 63 020 480	Lowering lever
H 018	G 13 000 998	Tension pin for lowering lever
H 019	G 01 020 491	Threaded pin
H 020	G 01 020 500	Hexagon nut
H 021	G 63 020 125	Tank
H 022	G 63 020 135	Tank fastening screw
H 023	G 63 020 136	Sealing ring fastening screw
H 024	G 63 020 130	Tank cap
*	G 63 020 600	Seal kit

* Contents gasket set G 63 020 600

1 x G 03 020 030
1 x G 03 020 201
1 x G 03 020 203
1 x G 03 020 390
1 x G 63 020 120
1 x G 63 020 136
1 x G 63 020 162

Attention!

If you are replacing the H 021 tank, tighten the H 022 retaining bolt at a maximum torque of 6 Nm.

WHEEL- AND PARKING BRAKE, EXPLOSIVE DRAWING

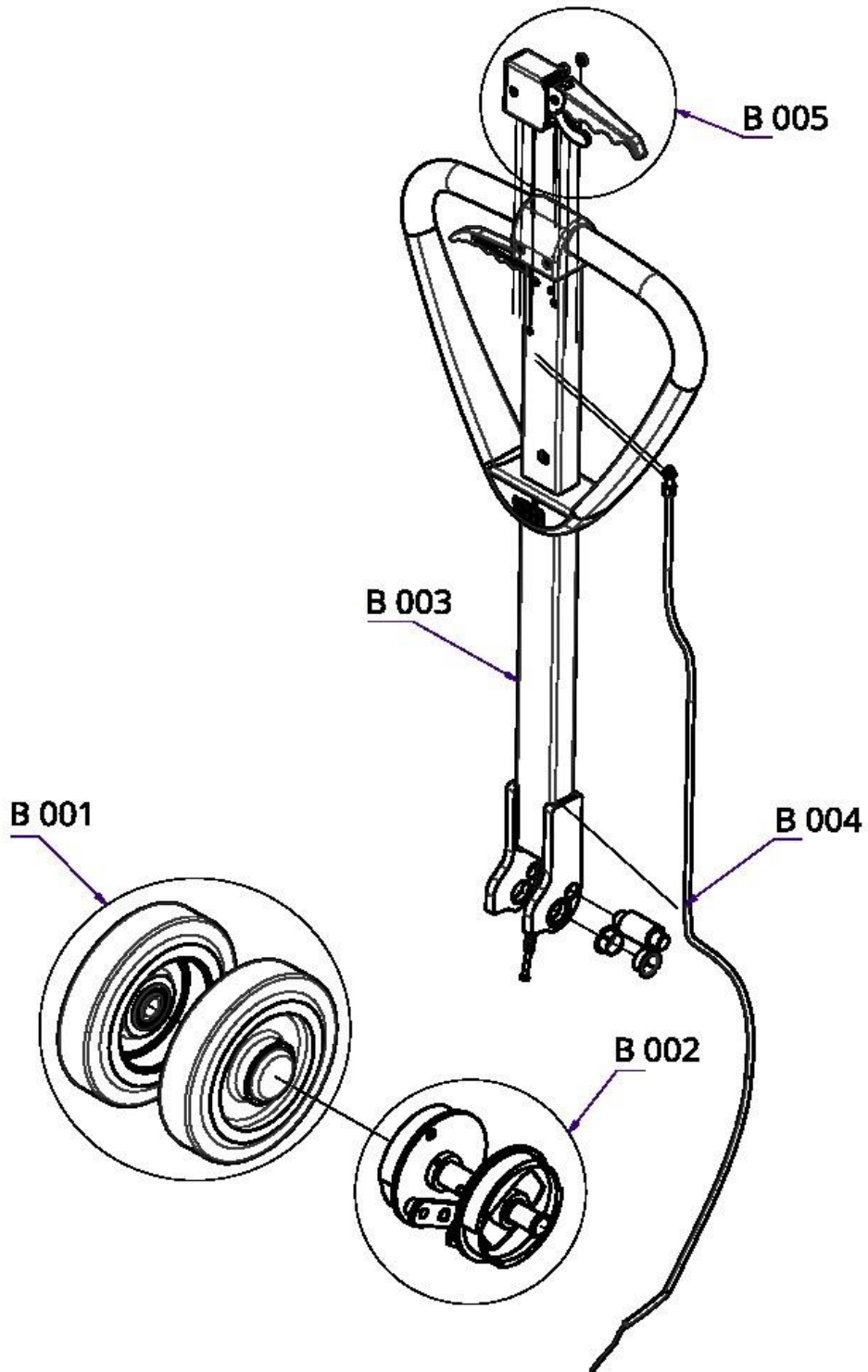

Wheel- and parking brake:

Fig. No.:	Order No.:	Designation:
B 001	G 23 007 360E	2x Front wheels for trolley with brake, Rubber
	G 13 007 405E	2x Front wheels for trolley with brake, Polyurethane
B 002	G 63 007 700E	Brake, set without wheels
B 003	G 63 007 031	Brake tiller handle, complete
B 004	G 13 007 750	Brake cable, complete
B 005	G 23 007 361	Brake lever

All items which are not listed are as used in the standard truck.

Attention!

If you are ordering part nos. F 001 and F 006 for the chassis, the complete forklift truck will have to be returned to the manufacturer's plant.