

FASSHEBER

**OPERATION INSTRUCTIONS
SPARE PARTS LIST**

FH 201



1 Declaration of Conformity

All information you need for the use and maintenance of your low loader can be found in this operating manual. Before switching on the car, read the owner's manual carefully and follow the instructions contained therein. They help you prevent accidents and maintain the warranty conditions and therefore their validity.

The pallet truck described in this manual is manufactured using the most modern technological processes. During construction, all applicable safety standards and regulations were observed.

VMH - Material Handling s.r.o. Sabinovská 53, 082 21 Veľký Šariš, SLOVAKIA



Tel.: 00421 51 7495160
Fax.: 00421 51 7495160
E-mail: vmh@vmh.sk
Web: www.vmh.sk



The declaration of conformity indicates that a forklift truck complies with the relevant directives at the time it is placed on the market:

- * CE: European Union (EU)
- * UKCA: United Kingdom of Great Britain (UK)

The Declaration of Conformity is issued for the EU and United Kingdom (UK) markets.

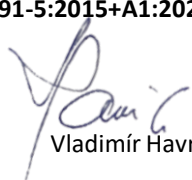
<p>* * * EC Declaration of Conformity * * *</p> <p>to EC Machinery Directive: 2006/42/EC</p> <p>Producer: VMH–Material Handling, s.r.o., Sabinovská 53, SK-082 21 Veľký Šariš, Slovakia</p> <p>Reg. Nr.: 45 452 237</p> <p>We, represented by the undersigned, here by declare that the following machinery:</p> <p>FASSHEBER</p> <p>FH 201 with capacity 300 kg</p> <p><i>(also, with additional components and derivations)</i></p> <p>conforms to the following relevant provisions / directives:</p> <p>EC Machinery Directive 2006/42/EC</p> <p>Further standards / specifications / documents used in the form of</p> <p>Harmonisierte Normen: EN ISO 12100:2010</p> <p>EN ISO 3691-5:2015+A1:2020</p> <p>Veľký Šariš, Slovakia 25.04.2024</p> <p> Vladimír Havrila</p>



IMPORTANT

- *Unauthorized interventions or changes to the structure of the pallet truck can lead to injuries and a general safety hazard in the workplace. Such an intervention in the structure will result in the declaration of conformity becoming invalid.*

2 Table of contents

1	DECLARATION OF CONFORMITY	2
2	TABLE OF CONTENTS	3
3	INTENDED USE	4
4	LIABILITY AND WARRANTY	5
4.1	CHANGES TO INDUSTRIAL TRUCKS.....	6
5	GENERAL SAFETY INFORMATION	7
5.1	PRINCIPLES	7
5.2	PROTECTIVE DEVICES	7
5.3	ORGANIZATIONAL AND PERSONNEL RULES OF CONDUCT	8
5.4	PERSONAL PROTECTION EQUIPMENT (PPE).....	9
5.5	WARNINGS AND EXPLANATION OF SYMBOLS	10
6	PRODUCT DESCRIPTION.....	11
6.1	DESIGNATION OF PARTS.....	11
6.2	PRODUCT SPECIFICATION	12
6.3	NAMEPLATE, BEARING LOAD DIAGRAM	12
6.4	PRODUCT IDENTIFICATION	13
6.5	AMBIENT CONDITIONS	15
7	START-UP	16
8	OPERATION.....	17
8.1	SAFETY INSTRUCTIONS	17
8.2	DEVICE-SPECIFIC SAFETY INSTRUCTIONS	19
8.3	OPERATING AND DISPLAY ELEMENTS.....	20
8.4	WORKPLACE.....	21
8.5	OPERATING.....	22
8.6	BRAKING	23
8.7	ADVICES FOR CORRECT LOAD TAKE-UP	24
8.8	TAKING UP AND PUTTING DOWN THE TRANSPORT LOAD.....	25
8.9	LIFTING A LOAD, LOWERING A LOAD.....	27
8.10	ADVICES FOR TRANSPORT OF THE LOAD	29
8.11	STOP / PARK	30
9	FIRST AID IN CASE OF MALFUNCTIONS.....	31
9.1	POTENTIAL CAUSES OF MALFUNCTIONS AND TROUBLE SHOOTING	32
10	MAINTENANCE.....	33
10.1	FOR YOUR SAFETY.....	33
10.2	MAINTENANCE WORK WHICH MUST BE PERFORMED DAILY	35
10.3	MAINTENANCE WORK, 500 OPERATING HOURS / HALF-YEARLY	36
10.4	MAINTENANCE WORK, 1000 OPERATING HOURS / ANNUAL	37
10.5	MAINTENANCE WORK, 2000 OPERATING HOURS / EVERY TWO YEARS	38
10.5.1	OIL CHANGE.....	40
11	DECOMMISSIONING / RECOMMISSIONING.....	42
12	TRANSPORTING THE TRANSPORT TRUCK, DELIVERY CONDITION	43
13	SPARE PART LIST	45
13.1	COMPLETE DEVICE	45
13.2	DRUM CLAMP	47
13.3	GUIDE PULLEY	48
13.4	LIFTING CYLINDER	49
13.5	COUPLING PIECE.....	51
13.6	CYLINDER	52
13.7	ORDERING SPARE PARTS	53
14	ANNEX: BOLTING TORQUES.....	54
15	ANNEX: LUBRICANT TABLE	55

3 Intended use

This chapter provides information about how to avoid reasonably foreseeable misuse.

In general, the following is regarded as intended use:

- For lifting, lowering and transporting loads according to the order specifications.
- 1-person workplace
- Only use trained personnel

Refrain from any misuse:

- Prevent unauthorized persons from using the product.
- Keep other persons away from the working range of the industrial truck.
- Refrain from using the product on sloping or uneven floor surfaces.
- Refrain from using the product in a damp environment as well as outside enclosed buildings.
- Refrain from using the product in explosive atmosphere.
- Refrain from using the product in a cool environment, e.g. a cold storage house, in long-term operation.
- Only use the product according to the order specifications.

4 Liability and warranty

Liability and warranty will be excluded if:

- the information and directions in the operating instructions are not complied with,
- the specified maintenance cycles are not complied with,
- the product is not used in accordance with its intended purpose,
 See "Intended use"
- modifications and functional changes are performed,
- safety device are modified,
- no original spare parts are used.

Warranty claim

During the warranty period, the manufacturer or a service and distribution partner authorized by the manufacturer must exclusively be contacted.

If any case occurs which is covered by warranty, a warranty claim must be filed with the manufacturer or the service and distribution partner authorized by the manufacturer in advance.

During the warranty period, only the manufacturer or the service and distribution partner authorized by the manufacturer is allowed to perform the maintenance work stipulated in the operating instructions as well as the statutory, annual examination according to the rules for the prevention of accidents according to DGUV V68.

All maintenance work must be documented in a test record.

The following wearing parts are excluded from warranty:

- driving wheels
- other wearing parts
- auxiliary materials and operational equipment

The "Sales terms and delivery conditions of **VMH - Material Handling s.r.o.** apply to any warranty claim towards the manufacturer.

4.1 Changes to industrial trucks

The term “industrial trucks” includes all kinds of lifting and transporting equipment.

- ▶ Unauthorised modifications to industrial trucks may not be made without the previous written consent of the manufacturer of the original hoisting equipment or his successor.

This relates to the following changes:

- Modifications which, for example, relate to the load carrying capacity, structural stability, or safety requirements.
- Modifications which affect, for example, braking, steering or vision.
- Adding detachable fitments.

If the manufacturer or his successor declare their consent to such a modification, they must also make and approve the corresponding changes on the signboards indicating the load carrying capacity, on the labelling and stickers as well as in the operating and maintenance manuals.

- ▶ Operating entities may only make changes, or have changes made, to industrial trucks if the industrial truck manufacturer has withdrawn from the business and there is no business successor; however, the operating entity must:
 - ensure that the modifications to be made and their safety are planned, inspected and executed by a specialist engineer for industrial trucks;
 - have permanent records of the design, inspection(s) and execution of the modification;
 - make and approve the corresponding changes on the signboards indicating the load carrying capacity, on the notices and the stickers as well as in the operating manuals and workshop manuals and
 - make a permanent and easily visible marking on the industrial truck, which show the type of modification or refitting that has been made, the date of the modification or refitting, and name and address of the organization entrusted with carrying out with this task.

5 General safety information

This chapter informs you about the residual risks and hazards in case of proper usage of the product. Safety instructions which are generally valid or which must be observed in general are listed here.

Safety instructions which refer to a particular action or situation are placed in front of the relevant action step or the description of the situation.

5.1 Principles



IMPORTANT NOTE!

- *Protect yourself and prevent your device from getting damaged.*
- ▶ Prior to first use, read the operating instructions at all costs.
- ▶ Keep the operating instructions in a safe place and hand them over to any subsequent owner.

This product corresponds to the state of the art and the recognized safety-related regulations. Nevertheless, danger might arise from it.

- Only use the product in an excellent condition, considering the operating instructions.
- In all phases of the product service life, make sure the product will be safely integrated into its environment, as far as this can be realized.
- Refrain from modifying and changing the product.

5.2 Protective devices

Information about the meaning of protective devices.



CAUTION!

- *It is prohibited to remove or disable protective devices on industrial trucks or other load handling devices.*
- *The use of industrial trucks or other load handling devices without mandatory protective devices is prohibited.*
 - ⇒ *There may be safety risks for the operating person if industrial trucks or other load handling devices are used without protective devices.*

5.3 Organizational and personnel rules of conduct

Consider the following rules of conduct and reduce the risk of accidents and damage in this way.

If any accident or damage occurs, the judicial authority will also examine the compliance with the organizational responsibility. Misbehaviour may be punished, up to personal liability.

As a matter of principle, safe operation requires professional preconditions and the personal suitability of each person. Enclosed you will find some normative definitions for better comprehension.

According to EN 50110-1, a person responsible for work is “a person appointed to assume direct responsibility for the performance of such work. If required, this responsibility can be partially delegated to other persons. [...] The person responsible for work must inform all persons involved in such work about any danger which is not clearly recognizable or visible for them”.

According to IEC 60204-1, specialists are “persons who, due to their relevant professional training and their experience, are qualified to recognize risks and to avoid potential hazards”.

According to DIN 31000, an instructed person is someone “who has been advised and, if required, trained on the tasks assigned to such person and on the potential hazard arising from improper behaviour and who has been instructed on the necessary protective devices and precautions”.

According to the DGUV V68 regulations of the employer's liability insurance association, a technical expert is someone “who, due to his/her professional training and experience, has sufficient knowledge in the area of industrial trucks and who is familiar with the relevant national worker's protection rules, the rules for the prevention of accidents, the guidelines and the generally recognized engineering rules to such an extent that he/she can evaluate the safe operating condition of industrial trucks”.

- Supplement the operating instructions with instructions from existing national regulations for accident prevention and environmental protection.
- Organise the safest possible work sequences.

What needs to be done?	Who is responsible for execution?
<ul style="list-style-type: none"> • Select and instruct staff • Train staff • Only employ trained personnel, allocate authorizations • Analyse operational dangers • Implement low-risk operation (define work areas, specify and confirm driveways, identify danger points on driveways by conventional road traffic signs and, if necessary, by additional warning signs) • Produce instruction manuals • Repeat instruction periodically (at least 1x annually, • Record topic and participants and have signature confirmation) • Provide the necessary protective clothing • Notify the manufacturer of product and/or operating instructions faults and deficiencies 	Designated representative
<ul style="list-style-type: none"> • Operating transport truck • Reporting and registration of faults • Carrying out maintenance 	Operator
Mechanical operations	Mechanic
Annual check of transport truck	Service: VMH - Material Handling s.r.o. , according to definition by competent person
Transport truck transportation	Skilled transport personnel
Maintenance	Use qualified and suitably trained specialist staff for these tasks or
Repairs	Service: VMH - Material Handling s.r.o.

5.4 Personal Protection Equipment (PPE)

General information and rights and responsibilities related to the personal protection equipment are specified here. The necessity for and selection of the personal protection equipment must be determined by a hazard assessment.

Employer

The employer must make available all the protective equipment that is required by the employee for performing his activities.

The protective equipment must not be a replacement for the technical and organisational measures for avoiding danger to health.

The employee must be instructed in the use of the protective equipment. This includes the use, the usage limits, the duration of wearing, care and storage of the protective equipment.

Employee

The employee is obligated to use the personal protection equipment provided by the employer. Every time before it is used, the protection equipment must be inspected for functional capability and to check whether it is damaged. Defective protective equipment must be replaced immediately.

The most important protective equipment is:

- Safety helmet
- Falling objects or projecting parts can cause serious head injuries.
- Ear protection
- Noise is among the biggest environmental and health hazards.
- Gloves
- They provide protection from sharp edges, afford more slipping resistance when gripping things, and depending on their quality, they help avoid contact of the skin with dangerous substances.
- Safety shoes
- Shoes with protective caps at the toes prevent serious injuries.
- Gas masks
- Poisonous, corrosive gases and dust of all kinds are foreign bodies for the organism. Continuously inhaling such foreign bodies results in damage to the respiratory tract.
- Goggles
- Protective goggles provide good protection for the eyes when working with solid or liquid (chemical) elements and when working in situations where dust is generated.



CAUTION!

- ▶ Operation and maintenance of the device / vehicle may only be performed with the personal protection equipment (PPE) provided for the purpose.
 - ↻ Performing activities without PPE can result in personal harm in moments of inattentiveness.
-
-

5.5 Warnings and explanation of symbols

The signal words DANGER – WARNING – CAUTION classify the potential degree of danger of a bodily injury in a specific situation.

Injuries can be avoided if the indicated rules of conduct are complied with. The hazard warning triangle symbolizes a 'General hazard'.



DANGER!

Alerts to an imminent danger.

Non-observance of the warning notice may cause serious injury or death.



WARNING!

Alerts to a possible dangerous situation.

Non-observance of the warning notice may cause serious injury or death.



CAUTION!

Alerts to a possible harmful situation.

Non-observance of the warning notice may cause injury.



ATTENTION

Alerts to a possible property damage without bodily injury.

Non-observance of the warning notice may cause property damage.



Tip for the user / information

Alerts to recommendations for use and other useful information.

Legend of the symbols used in this document

Warning texts

- *Warning texts point to possible dangerous situations during the operation.*
- ⇒ *Effects of such dangerous situations are marked by this symbol.*

Instructions and guidelines which are relevant to safety

- ▶ Instructions and guidelines which help to ensure safety for people and machines are marked by this sign.
- ↻ The execution of these safety-relevant instructions and guidelines is marked by this sign.

Instructions and guidelines

- Instructions and guidelines which are clear and easy to understand are marked by this sign and stated as a list.
- ↻ Results of actions are marked by this sign.

Sequences of action

- ➔ Sequences of action in the case of which it is mandatory to follow the specific sequence are marked by this sign.
- ↻ Results of sequences of action are marked by this sign.

Reference

- 🔗 *This sign points to references made in the current section of the operating instructions to other sections of the operating instructions.*

Preview text

This sign points to brief summaries of sections in the operating instructions.

6 Product description

This chapter provides you with useful information about the structure and function of the product.

We reserve the right to make technical and optical changes. Errors and misprints excepted.

6.1 Designation of parts

In this section, those parts are designated which are important for easy comprehension afterwards.

Typical operating and display elements are shown in the following section.

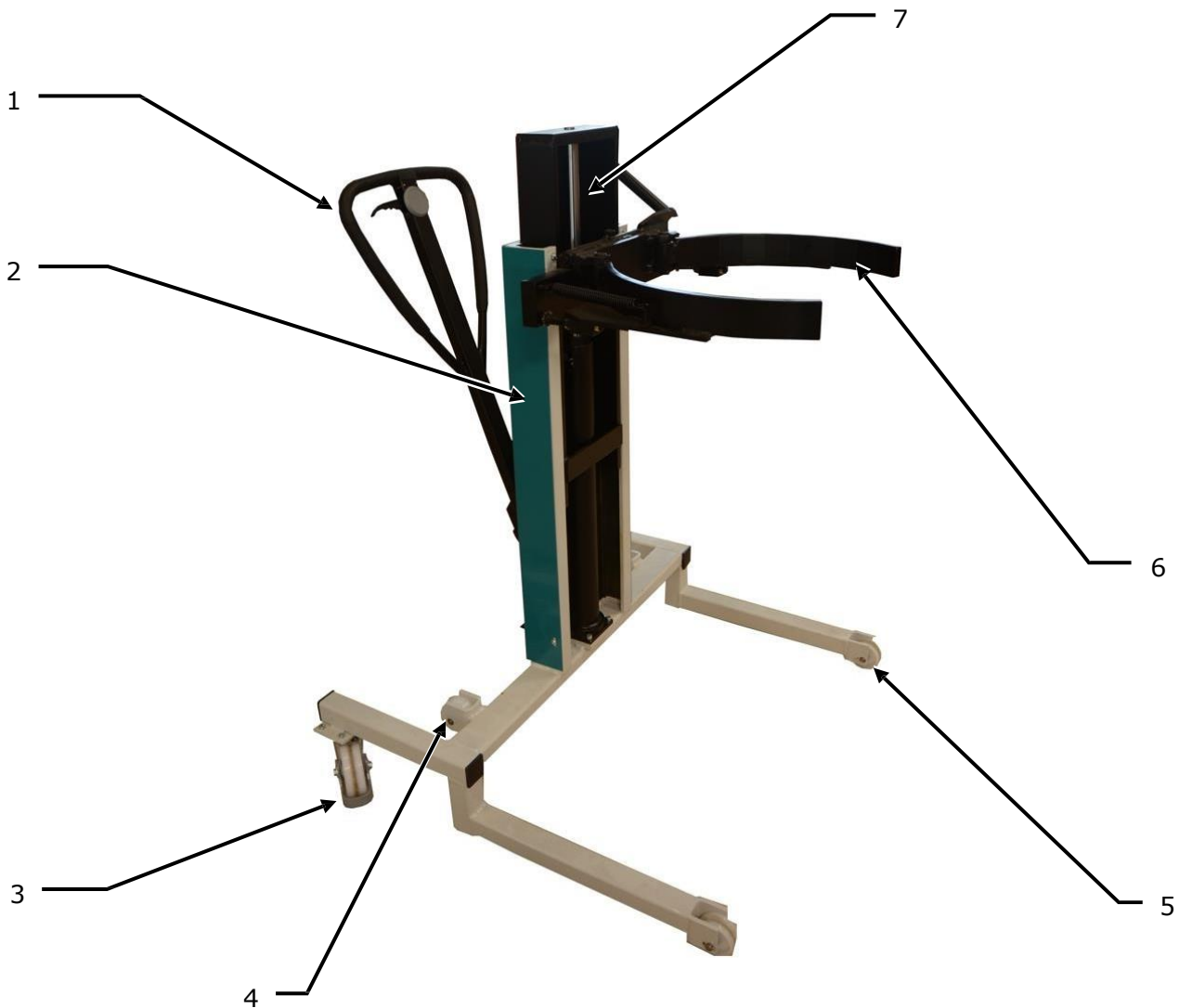

1 Drawbar

2 Lifting frame

3 Steering roller with brake

4 Support roller

5 Running wheels

6 Gripping jaw

7 Lifting cylinder

6.2 Product specification

The key technical data of the product and the requirements for the conditions of utilization are given here.

6.3 Nameplate, bearing load diagram

Here, designations and performance characteristics of your product are indicated. Pay attention to the performance characteristics of your product.

Type:	FH 201
Serial no.:	See nameplate
Year of manufacture:	See nameplate
Nominal carrying capacity:	300 kg
Weight of truck without battery:	See nameplate
VMH - Material Handling s.r.o. Sabinovská 53, 082 21 Veľký Šariš, SLOVAKIA	
	
Tel.: 00421 51 7495160 Fax.: 00421 51 7495160 E-mail: vmh@vmh.sk Web: www.vmh.sk	
	



6.4 Product identification

The product identification locations are indicated here. Check agreement with your product.



Special symbols and pictographs

Some types of hazard are illustrated by special symbols.

1		The transport of persons on the transport device is prohibited	20		Possible personal injury or property damage
2		It is prohibited to ride on the transport device	21		Risk of crushing legs and feet
3		Do not ride on the load pick up device	22		Risk of crushing hands
4		Do not step under lifted load	23		Warning of laser beam
5		Caution! Always transport cargo in the lowered condition	24		Electric current
6		It is prohibited to step on the area	25		Warning tape for marking possible danger spots
7		Do not operate or park the transport device outside closed buildings	26		Slings points for device transports
8		Passenger transport prohibited	27		Wear safety footwear
			28		Fasten the seat belt
			29		Warning of crushing hazard
40		Nameplate	42		Inspection plate
41		Bearing load diagram	43		Bearing load shield
44		Switch lock			

6.5 Ambient conditions

Here, the permissible general conditions are indicated for the use of the machine.



Temperature	5°C - 30°C
Degree of humidity	≤ 70%
Admissible floor incline	
• when loaded	max. 0,5%
• when unloaded	max. 2,0%



ATTENTION

- ▶ The roadways must have a carrying capacity sufficient for the loaded truck. Insufficient floor conditions may cause damage to the floor or truck.

7 Start-up

This chapter informs you about the measures which are necessary if the product is used according to its intended purpose for the first time.

As-delivered condition



CAUTION!

- *A defective or faulty product might cause unforeseeable damage.*
- ▶ Convince yourself of the proper condition of the product prior to commissioning. Check the product for completeness and its excellent condition.

See also chapter "Transport of the industrial truck, as-delivered condition".

Operation



CAUTION!

- Unauthorized use may lead to unforeseeable danger.

Option

- Secure the industrial truck against unauthorized use.
For this purpose, pull off the key from the switch lock.
-

8 Operation

This chapter describes different scenarios during the operation.

8.1 Safety instructions

In addition to the chapter “General safety information”, safety instructions are provided which are specific to the relevant chapter.

Preconditions

- Each operator of an industrial truck has been instructed accordingly and has furnished proof of his/her capability to handle such truck to the operating company's responsible supervisor/person in charge.

Wear personal protective clothing



CAUTION!

- Sometimes it might happen that you hit your feet against objects or your feet get caught between objects or your shoes get scratched during work.



- ▶ Wear safety boots

Wear protective clothing while handling the battery (optional).

 See the enclosed instructions of the battery manufacturer.

Avoid carelessness, always behave attentively

From a statistical point of view, approximately every 1000th action is an erroneous action.

In case of industrial trucks, the number of accidents is disproportionately high. In the majority of cases, accidents are caused by carelessness or by violating most basic safety-relevant codes of conduct.

- Behave attentively and in a foresighted manner.

Memorize beforehand the use of the truck

- Exercise every scene without load until you can safely control the function.
- Do not use the product until you have finished exercising.

Unavoidable shear and pinch points on the industrial truck require a use of the truck as single-person workplace (optional)



CAUTION!

- *Unavoidable shear and pinch points may occur in the working range of the industrial truck. There is an increased danger of accident.*
- ▶ The truck is a single-person workplace. Keep unauthorized persons away.
- ▶ The workplace is on the drawbar / push handle / operator panel / driver's seat / driver station / stand-up operator's platform.

Only use the industrial truck on even floors



WARNING!

- *This industrial truck does not have a service brake. Risky behaviour means an increased risk of accident.*
- ▶ Always behave with foresight so that you can stop the truck with your physical strength when required.
- ▶ Always attentively adjust the travelling speed to the situation. Turn curves only at reduced speed.

Never stay under suspended loads



CAUTION!

- *There is a life threatening risk while staying in the area of the lifted load.*
- ▶ Never enter the area below the lifted load suspension device, regardless of whether the industrial truck is loaded up or empty.
- ▶ Keep a sufficient distance.



Never climb on the load or the load suspension device



CAUTION!

- *There is a life threatening risk while riding on the load or the load suspension device.*
- ▶ Refrain from riding on the load or the load suspension device.



8.2 Device-specific safety instructions

This section deals for example with shearing or crushing points on the device which may inevitably occur during the operation of the device, due to its particular design.

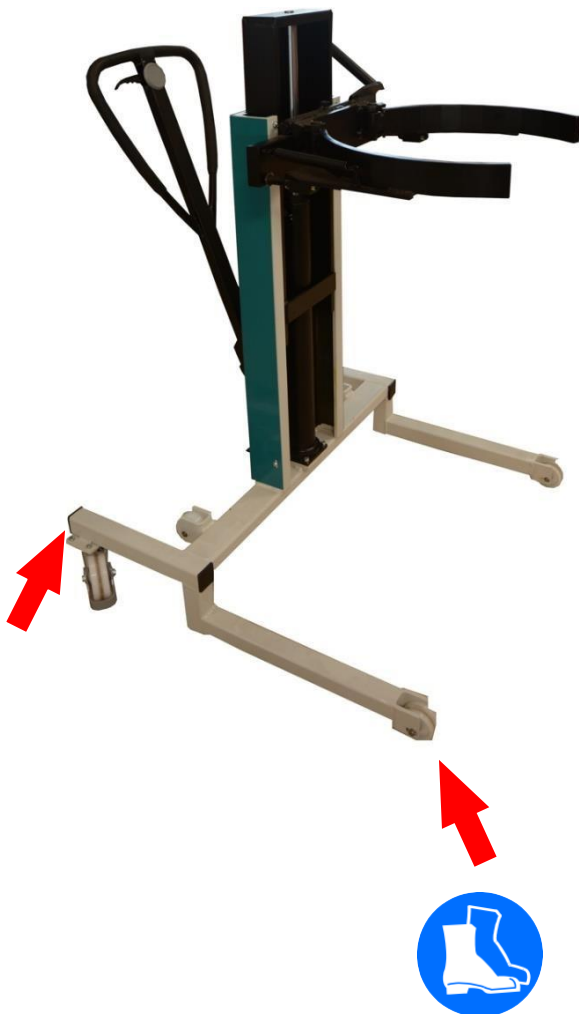

WARNING!

- *This industrial truck does not have a service brake. Risky behaviour means an increased risk of accident.*
- ▶ Always behave with foresight so that you can stop the truck with your physical strength when required.
- ▶ Always attentively adjust the travelling speed to the situation. Turn curves only at reduced speed.



CAUTION!

- *Be careful when handling the lifting device.*
- ⇒ *Please note that during the execution of the lifting device, there are inevitable crushing be produced.*



CAUTION!

- *The device is equipped with running wheels without foot protection.*
- ▶ While moving the device, pay attention to the rolling direction of the steering rollers.
- ▶ Wear safety footwear.

8.3 Operating and display elements

Here parts for which a slight understanding is important are named. The operation is explained in the chapter "Operation".



1	Drawbar	for steer push and draw the machine
2	Hand lever	for manually removing the drum clamps
3	Control lever	for lifting and lowering the load handling attachment
4	Pump lever / pedal	for lowering the load suspension device in an emergency situation
5	Locking brake	to lock the truck during parking, loading / unloading

8.4 Workplace

Here, the point is identified from which the machine is operated.



CAUTION!

- *Shearing and crushing areas are unavoidable in the entire working area of the machine.*
- ▶ Danger of injury. For this reason, only the operator may be permitted to remain in the working area of the equipment.
- The work station for the operator is the drawbar / pushing bar / operator panel / driver seat / operator's platform / remote control.

8.5 Operating



WARNING!

- *This industrial truck does not have a service brake. Risky behaviour means an increased risk of accident.*
- ▶ Always behave with foresight so that you can stop the truck with your physical strength when required.
- ▶ Always attentively adjust the travelling speed to the situation. Turn curves only at reduced speed.

- Push or pull the truck at the pushing bow only (drawbar).

8.6 Braking



WARNING!

- *This industrial truck does not have a service brake. Risky behaviour means an increased risk of accident.*
- ▶ Always behave with foresight so that you can stop the truck with your physical strength when required.
- ▶ Always attentively adjust the travelling speed to the situation. Turn curves only at reduced speed.

Parking brake



To activate the parking brake press firmly on the lug.



To release the parking brake press firmly against the lug.

8.7 Advices for correct load take-up

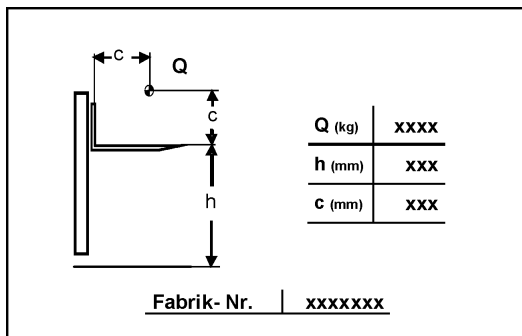

WARNING!

- *Too high or incorrect strain may cause damage to the product or possibly bodily injury.*
- ▶ Make sure that the carrying capacity of the truck is not exceeded. Follow the indications as per product labelling.
 - ↻ An inadmissibly loaded truck means a source of danger for its environment.
- ▶ Take up the load to be handled only by the device destined for the handling.
 - ↻ Another way of load take-up means danger to person and machine.
- ▶ Never exceed the weight of the loads indicated in the load diagram.
 - ↻ Wrongly taken up transport load increases the danger of tipping and the wear and tear of the truck.
- ▶ Take up the load in a stable and compact way. You have to avoid shift or falling down of the load.
 - ↻ Falling down load endangers man and machine.

8.8 Taking up and putting down the transport load



Preconditions:

- Vehicle is ready for operation

Further procedure:

Automatic pickup of cargo



CAUTION!

- ▶ Make sure the gripping jaws can pick up the cargo safely and completely.
 - ↳ If the cargo is picked up aslant or incompletely, it may slip out of the gripping jaws. This may lead to harm to persons or material damage.

- ▶ The drum must be full. Empty drums must be picked up manually.
- ▶ Lower the gripping jaws to about 150mm below the edge of the drum.
- ▶ Approach the upright barrel centrally.
- ▶ As soon as the gripping jaws reach the drum, they open automatically owing to the resistance of the drum and close automatically as soon as the drum is centred.
- ▶ Lift the drum.

Depositing the cargo



CAUTION!

- ▶ Make sure the cargo is deposited on an even surface.
 - ↳ The cargo could topple over on an uneven surface after opening the gripping jaws. This may lead to harm to persons or material damage.

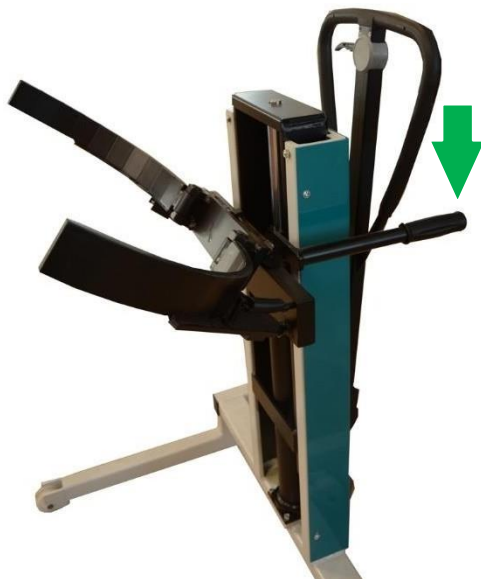

- ▶ Lower the drum till it is securely upright.
- ▶ Move back, the gripping jaws open automatically.

Manual pickup of cargo

- ▶ With light / empty drums, actuate the hand lever for picking up and depositing the drum.

Setting the drum diameter:

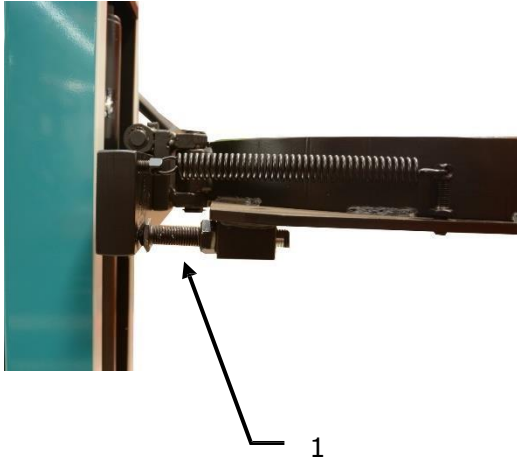

➤ Use a hexagon spanner (size 24) to set the adjusting screw (1) on the clamping jaws uniformly on both sides.

↻ Turning to the right ☐ Diameter is increased

↻ Turning to the left ☐ Diameter is reduced

8.9 Lifting a load, lowering a load



Preconditions

- The industrial truck is ready for operation.

Further procedure:

Raising the load suspension device

- Pull the operating lever down
- Carry out pumping movements with the drawbar.
 - ↳ The load lifting device is raised.

Lowering the load suspension device

- Pull the operating lever up
 - ↳ The load lifting device is lowered.

Optional:

- Actuate the pump lever / pedal

Adjusting the lowering speed

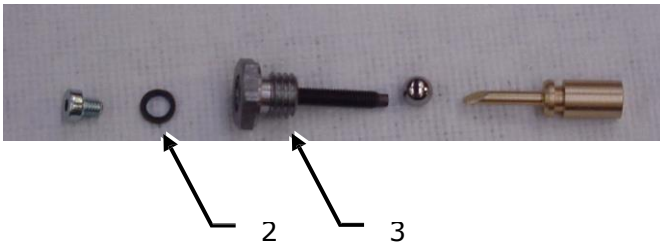

Preconditions:

- Load handling attachment has been lowered

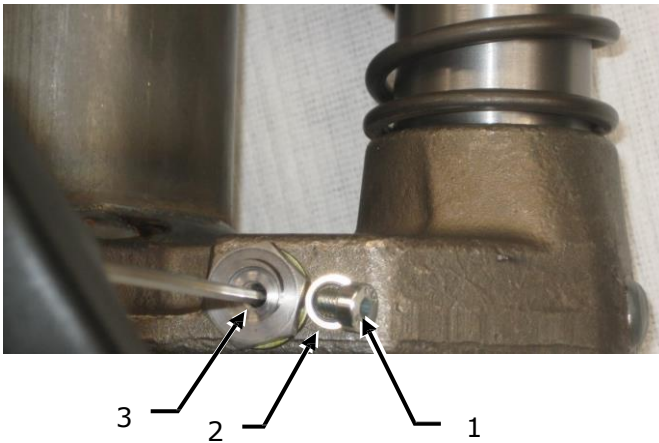

Further procedure:

- Unscrew the hexagon socket head screw (1) and remove the sealing ring (2). A small quantity of oil is discharged.
- Use the Allen key (size 2.5) (4) to adjust the adjusting screw (3).
 - ↺ Turn it to right ☑ Lowering speed reduces
 - ↻ Turn it to left ☑ Lowering speed increases



CAUTION!

- ▶ The entire adjustment range from minimum to maximum is between one-fourth and one-third of a revolution with the Allen key..

8.10 Advices for transport of the load



CAUTION!

- *Each transport of loads requires attentive and foresighted behaviour. There is an increased risk of accidents.*
- ▶ Only perform transports on even floors.
- ▶ Always transport loads in transport position.
- ▶ Always transport loads in the direction with the best view.
- ▶ Always attentively adjust your driving speed to the situations. Drive in curves at reduced speed.
- ▶ Empty trips may only be performed in transport position.



WARNING!

- *This industrial truck does not have a service brake. Risky behaviour means an increased risk of accident.*
- ▶ Always behave with foresight so that you can stop the truck with your physical strength when required.
- ▶ Always attentively adjust the travelling speed to the situation. Turn curves only at reduced speed.

8.11 Stop / park



CAUTION!

Due to pressure decrease in the hydraulic system, the 'load lifting device' might gradually lower. There is a risk of crushing.

- ▶ Completely lower the load-lifting device. This is the safest condition
- ▶ Prior to stopping/parking the product, unload it.
- ▶ Only stop and park the product on even floors.
- ▶ Depending on the vehicle equipment, secure the position by means of the 'locking brake' / 'parking brake'.



9 First aid in case of malfunctions

This chapter details first aid in case of malfunctions.



WARNING!

- A damaged transport truck can cause personal or material damage.
- ▶ In the case of a malfunction, bring the product immediately to a standstill until the cause of the malfunction has been detected and the fault remedied.



What needs to be done?	Who is responsible for execution?
Repairs	<ul style="list-style-type: none"> ● Service company: VMH - Material Handling s.r.o. ● Use qualified and suitably trained specialist staff for these tasks ● Electrical work is only to be carried out by trained electricians. <p><i>See chapter "General Safety Instructions" in these operating instructions</i></p> <p><i>See "Repair Guidelines incl. Spare Parts Catalogue" for this product</i></p>



DANGER!

- Before working on the hydraulic system, it is necessary to ensure that the system, including the pressure reservoir that is present, is rendered free of pressure.
- ⇒ Opening the hydraulic system under pressure results in harm to persons or damage to property.

Customer Service Information

VMH - Material Handling s.r.o. Sabinovská 53 082 21 Veľký Šariš SLOVAKIA		00421 51 7495160
		00421 51 7495160
		vmh@vmh.sk
		www.vmh.sk

9.1 Potential Causes of Malfunctions and Trouble Shooting

→ No hydraulic function possible

Possible cause:	Remedy:	Who is responsible for execution?
Oil quantity insufficient	Replenish hydraulic oil  See instructions in the chapter "Oil change"	Operator
Hydraulic pump faulty	➤ Dismantle hydraulic pump and send to VMH - Material Handling s.r.o. for repair.	Mechanic



WARNING!

- Very high pressure in the hydraulic system. Danger of injury.
- Depressurize hydraulic system completely before working.
- ▶ Support load pick-up unit securely.

→ Lifting is jerkily

Possible cause:	Remedy:	Who is responsible for execution?
Air in the system	Deaerate the hydraulic installation  See notes in chapter "Maintenance work to be done every 2 years".	Mechanic

→ Lowering isn't possible

Possible cause:	Remedy:	Who is responsible for execution?
Foreign particle in the guiding profile	Check guiding profiles and clean them if necessary	Operator

10 Maintenance

This chapter gives information about measures for preserving the serviceability of the product. Only by carrying out the maintenance measures correctly can trouble-free operation be achieved, unplanned down-times avoided and device safety contributed to.

10.1 For your safety



WARNING!

- *Missing or defective maintenance can cause personal and material damage.*
- ▶ Carry out maintenance work correctly and at the following specified minimum intervals.



WARNING!

- *A damaged transport truck can cause personal or material damage.*
- ▶ In the case of a malfunction, bring the product immediately to a standstill until the cause of the malfunction has been detected and the fault remedied.
Report the situation immediately to the responsible specialist staff or the after sales service.



ATTENTION

- *Incorrectly used fuel can cause material damage.*
- ▶ Use only the fuels and additives listed in the annex to these operating instructions.
- ▶ Only use spare parts which are listed in the spare parts catalogue.

What needs to be done?	Who is responsible for execution?
Maintenance	<ul style="list-style-type: none"> ● Use qualified and suitably trained specialist staff for these tasks ↳ <i>See instructions in the chapter "General Safety Instructions" in these operating instructions</i> ● VMH - Material Handling s.r.o. Service



DANGER!

- *Before working on the hydraulic system, it is necessary to ensure that the system, including the pressure reservoir that is present, is rendered free of pressure.*
- ⇒ *Opening the hydraulic system under pressure results in harm to persons or damage to property.*



CAUTION!

Safety devices

- ▶ After maintenance and repair work, all safety devices must be reinstalled and checked for proper operation.

Setting values

- ▶ After repair work and during the exchange of hydraulic and electrical components, the device-specific setting values must be observed.



CAUTION!

Mechanical precautionary measures

- ▶ It must be ensured that any unintentional movement of the vehicle is ruled out. For this purpose, actuate the brake, apply suitable chocks, securely jack up the vehicle, perform further measures.
- ▶ If maintenance work must be performed below the lifted load suspension device / lift mast, these subassemblies must be protected against falling down by sufficiently strongly dimensioned squared timber or chains.
- ▶ It must be ensured that the hydraulic system has been depressurized prior to opening the hydraulic lines. If the load suspension device / lift mast has to be lifted for this purpose, these subassemblies must also be protected against falling down.



PLEASE NOTE

- *Improper cleaning can damage the industrial truck.*
- ▶ NEVER clean the industrial truck with running water, high-pressure cleaners or solvents.



PLEASE NOTE

- ▶ Dispose of used oil, oily and greasy objects in an environment-friendly manner in keeping with the legal regulations.



PLEASE NOTE

- ▶ The industrial truck is made of different materials. Dispose of/recycle all materials in accordance with applicable regional/national regulations.
- ▶ We recommend working with a specialist waste disposal company.

What needs to be done?

Maintenance

Who is responsible for execution?

- Use qualified and suitably trained specialist staff for these tasks
See instructions in the chapter "General Safety Instructions" in these operating instructions
- VMH - Material Handling s.r.o. Service

Customer Service Information

VMH - Material Handling s.r.o. Sabinovská 53 082 21 Veľký Šariš SLOVAKIA		00421 51 7495160
		00421 51 7495160
		vmh@vmh.sk
		www.vmh.sk

10.2 Maintenance work which must be performed daily



No.	Subassembly / Component:	Measures:	Who is responsible for execution?
1.0	Complete transport truck	Inspect transport truck	Operator
	Complete transport truck	If necessary clean dry	Operator



WARNING!

- *The transport truck is possibly damaged or cannot be operated safely.*
- ▶ Always ensure perfect condition before using the product.
Look carefully at the product from several sides.

10.3 Maintenance work, 500 operating hours / half-yearly

➤ The measures must be taken every 500 operating hours, but at least once every six months, whichever comes first.

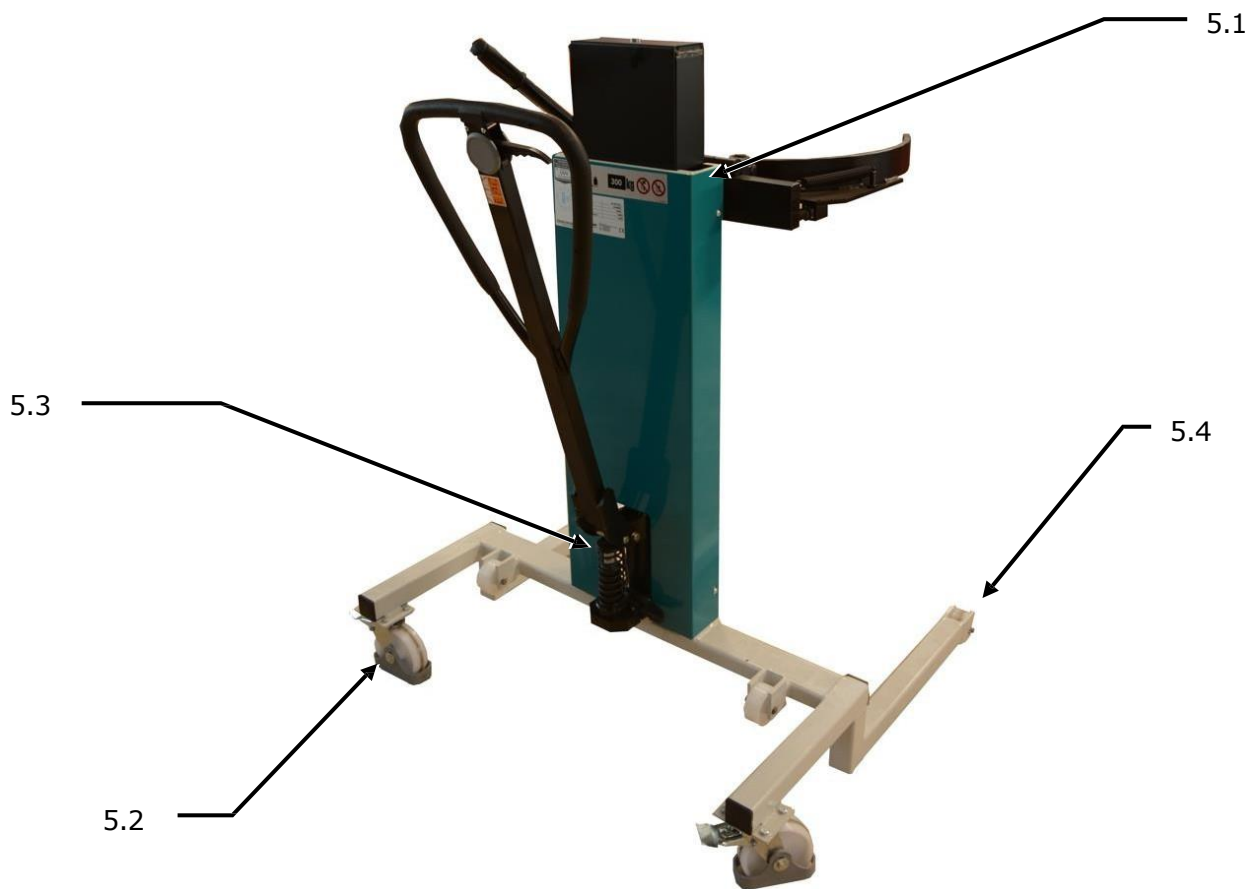

No.	Subassembly / Component:	Measures:	Who is responsible for execution?
		The last preceding maintenance work is an inherent part of the 500 hours / half-yearly maintenance work.	
5.1	Guiding profile	Grease the guiding / guide way by means of usual multi-purpose grease if necessary	Mechanic
5.2	Steering pulley	Check whether there is any damage. Dryly clean outer wheel bearings if necessary Take the measurements of the wheels and compare it with the admissible limit values as per product labelling	Mechanic
	Comparative value setting value / actual value	∅125mm / ∅115mm	
5.3	Foot pump	Check function, replace component if necessary. Check oil level, top up with oil if necessary. <i>See chapter "Oil change"</i>	qualified and instructed personnel
5.4	Running wheels	Check whether there is any damage. Dryly clean outer wheel bearings if necessary Take the measurements of the wheels and compare it with the admissible limit values as per product labelling	Mechanic
	Comparative value setting value / actual value	∅75mm / ∅65mm	

10.4 Maintenance work, 1000 operating hours / annual

- The measures must be taken every 1000 operating hours, but at least once a year, whichever comes first.

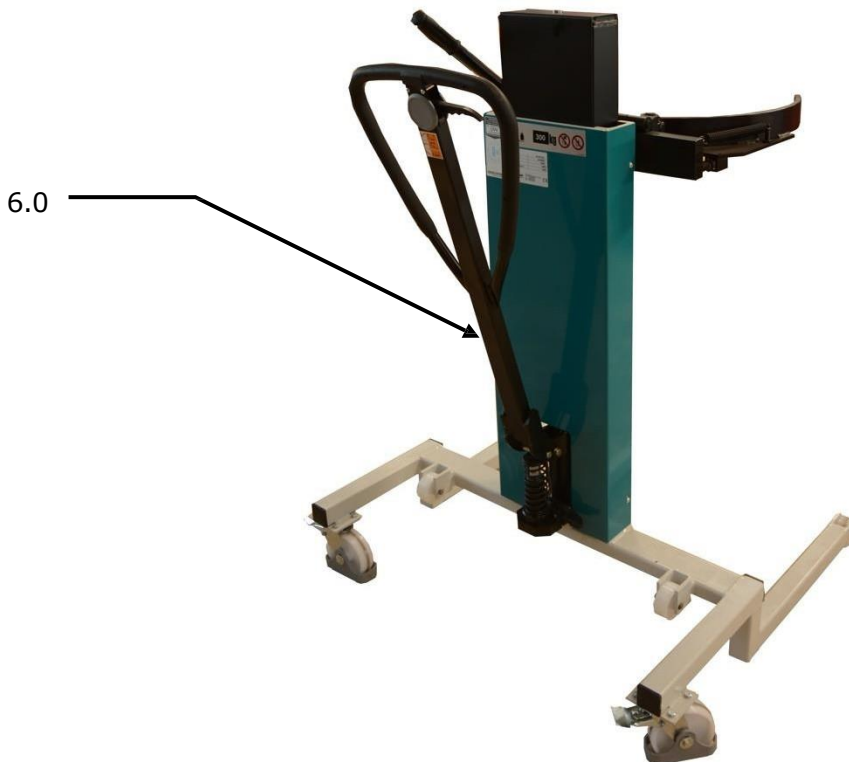

No.	Subassembly / Component:	Measures:	Who is responsible for execution?
		The 500 hours / half-yearly maintenance work is an inherent part of the 1000 hours / yearly maintenance work.	
6.0	Complete transport truck	UVV testing as per the test book. Test book FEM 4.004 for motor-driven transport trucks; Test book BGG 941 for manually operated transport trucks. <i>See manufacturer's user tips listed above</i>	specifically authorized specialists
	Labelling	Inspect signboards for completeness and readability. <i>See chapter "Product designation".</i>	specifically authorized specialists



WARNING!

- The examination of the industrial truck to be performed annually is a minimum requirement, since otherwise there is an increased danger of accidents.
 - ▶ Have the UVV (German accident prevention regulations) inspection performed at least once a year.
 - ▶ Ensure that the maintenance work to be carried out annually is performed.
- Have the aforementioned work performed by the VMH - Material Handling s.r.o. service staff. This gives you more safety. We recommend that the authorised technical specialist should at least be trained and instructed by the manufacturer, VMH - Material Handling s.r.o., for your product. Our Service department will be happy to quote for the product training.

10.5 Maintenance work, 2000 operating hours / every two years

- The measures must be taken every 2000 operating hours, but at least every two years, whichever comes first.

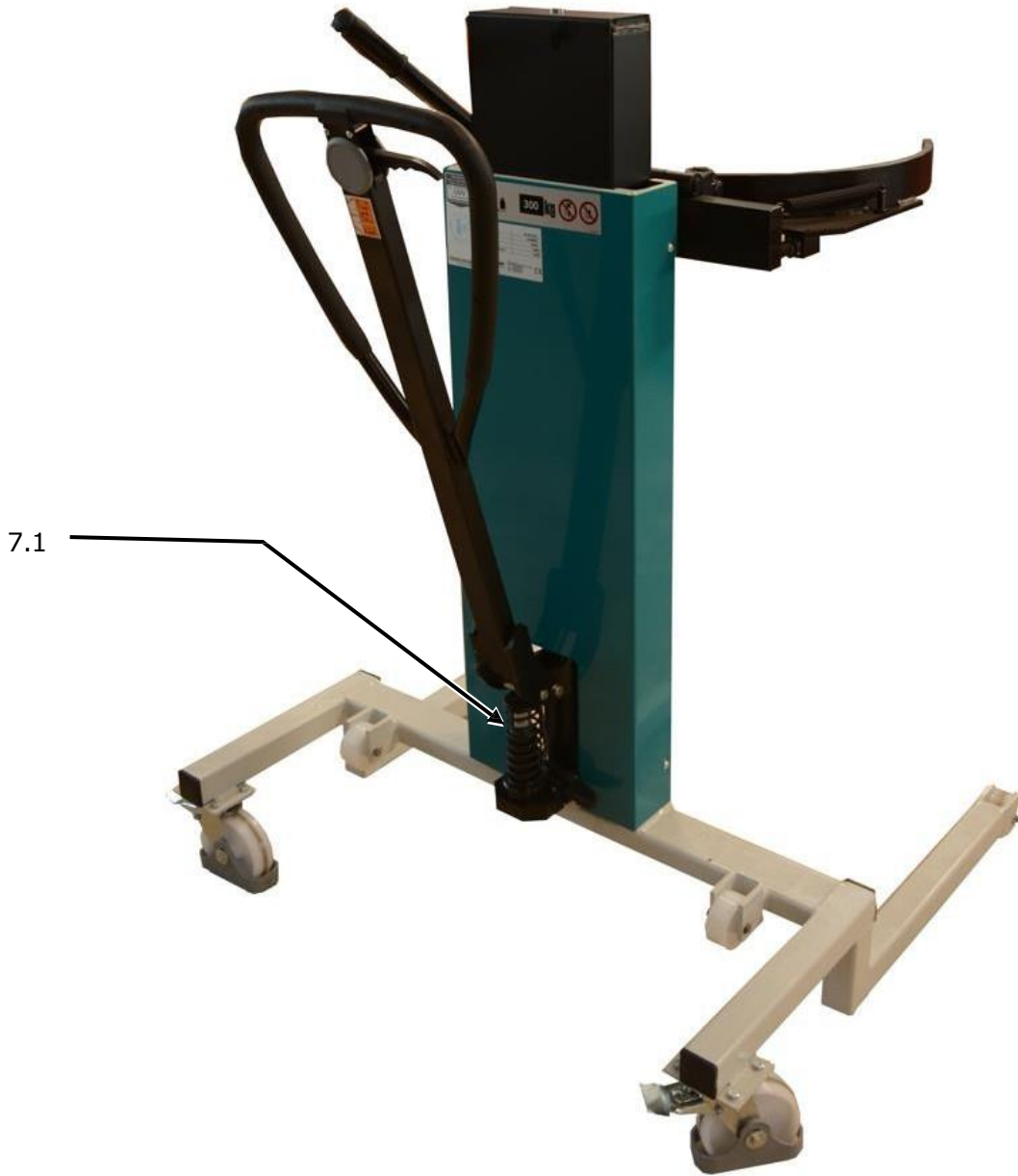

No.	Subassembly / Component:	Measures:	Who is responsible for execution?
7.1	Hydraulic	Renew hydraulic oil <i>See "oil change"</i>	Mechanic

Instructions for changing oil and venting the system



ATTENTION

- *The hydraulic unit must not be switched on with an empty oil tank.*
 - ↳ "Dry-running" may cause destruction of the pump..



ATTENTION

- *Incorrect oil use can cause damage.*
 - An unventilated system will destroy the seals.*
 - ▶ Observe the oil manufacturer's instructions.
 - ▶ Always mark the oil type, oil quantity and date of the last oil change on the product.
 - ▶ Dispose of used oil in an environmentally compatible manner in accordance with statutory requirements.
 - 🔗 *See annex "Lubricants" in these operating instructions*
 - ▶ Bleeding the hydraulic system.



ATTENTION

- *Type of oil used ex factory for this type of truck.*
 - with foot-operated hydraulic system Divinol DHG ISO 22
 - with electrical hydraulic system Divinol DHG ISO 46

10.5.1 Oil change



ATTENTION

▶ In the case of foam formation, discoloration of the oil or odour formation, change the oil immediately.



Id.-Nr. 70500592

Oil change:

- Lower the load pick-up unit completely.
- Remove the screw plug (1).
- Extract the oil through this opening.
- Pour in the new hydraulic oil exactly up to the mark.
- Clean the screw plug with compressed air and screw it in again.

Bleeding:

- Open the bleed screw (2) on the lift cylinder with the load pick-up unit lowered.
- Raise the load pick-up unit until oil exits free of bubbles; catch the exiting oil in a rag.
- Screw the bleed screw (2) in again



Divinol DHG ISO 22
Tank capacity about X liters
 X = 1,45

11 Decommissioning / Recommissioning

When the transport truck is shut down for more than 2 months:

- Jack up the vehicle so that all the wheels are raised off the ground.
This prevents permanent deformation of the wheels.
- Thoroughly dry clean the transport truck.
- The lifting device might have to be supported by suitable supports, to relieve the load chains
- Check oil level, top up if required.
- Lubricate the vehicle.
- Give thin oil and grease film to all bright and moving parts.
- The vehicle storage place must be dry, frost and dust free.
- Use a plastic sheet to cover the vehicle, otherwise the formation of condensation water and hence rust formation will be facilitated.

Additional measures

- Isolate the batteries from the on-board electrics.
- Charge the batteries.
- Clean the battery top and pole connections.
- Lubricate the pole connections with some pole grease.
- Check the electrolyte level, top up if necessary (not required for maintenance-free or gel batteries).
- Repeat charging of the batteries at least every 90 days, charge gel batteries at least every six months
- Spray exposed electrical contacts with a suitable contact spray.

Recommissioning after extended standstill periods

- Clean and lubricate the vehicle thoroughly.
- Remove the applied protective grease film.
- Renew the oil after a shut-down of more than 12 months.
- Check hydraulic hoses for brittleness.
- Check vehicle operation, especially the safety equipment.

Additional measures to be performed on trucks with integrated batteries

- Isolate the batteries from the on-board electrics.
- Charge the batteries.
- Check the electrolyte level, top up if necessary (not required for maintenance-free or gel batteries).

Final decommissioning

If a defective truck can no longer be repaired so as to permit adherence to valid safety regulations in accordance with its intended application, then the truck must be decommissioned.

- Dispose of vehicles dismantled into individual components (steel, plastic, electronics, fuel etc.) in accordance with the environmental regulations in force.

12 Transporting the transport truck, delivery condition

Transport



WARNING!

- *Accidents always happen with unprofessional transportation.*
- ▶ Transport may only be performed by a skilled transport operator.
- ▶ Danger of tilting. Only transport as shown.
- ▶ Only raise as high as necessary.
- ▶ Do not pull or drag the transport truck along askew.
- ▶ Keep other persons or unauthorized persons away



Delivery from foot hydraulic and hand mobile trucks



WARNING!

- *An unchecked truck condition increases the risk of accidents.*
- ▶ Check the truck for completeness and perfect condition.

- The hydraulic unit tank is filled.
- The whole hydraulic system has been assembled ready to operate.



13 Spare Parts List

Use only original parts of the manufacturer for maintenance or extension of your lift truck. There is no possibility of liability or guarantee for injury to persons or damage to property if:

- The lift truck is wrongly operated, cleaned or maintained.
- Modifications of function are done without consent of the manufacturer.
- No original spare parts are used.
- Maintenance is done improperly and by non-authorized persons.

13.1 Complete Device

Drawing

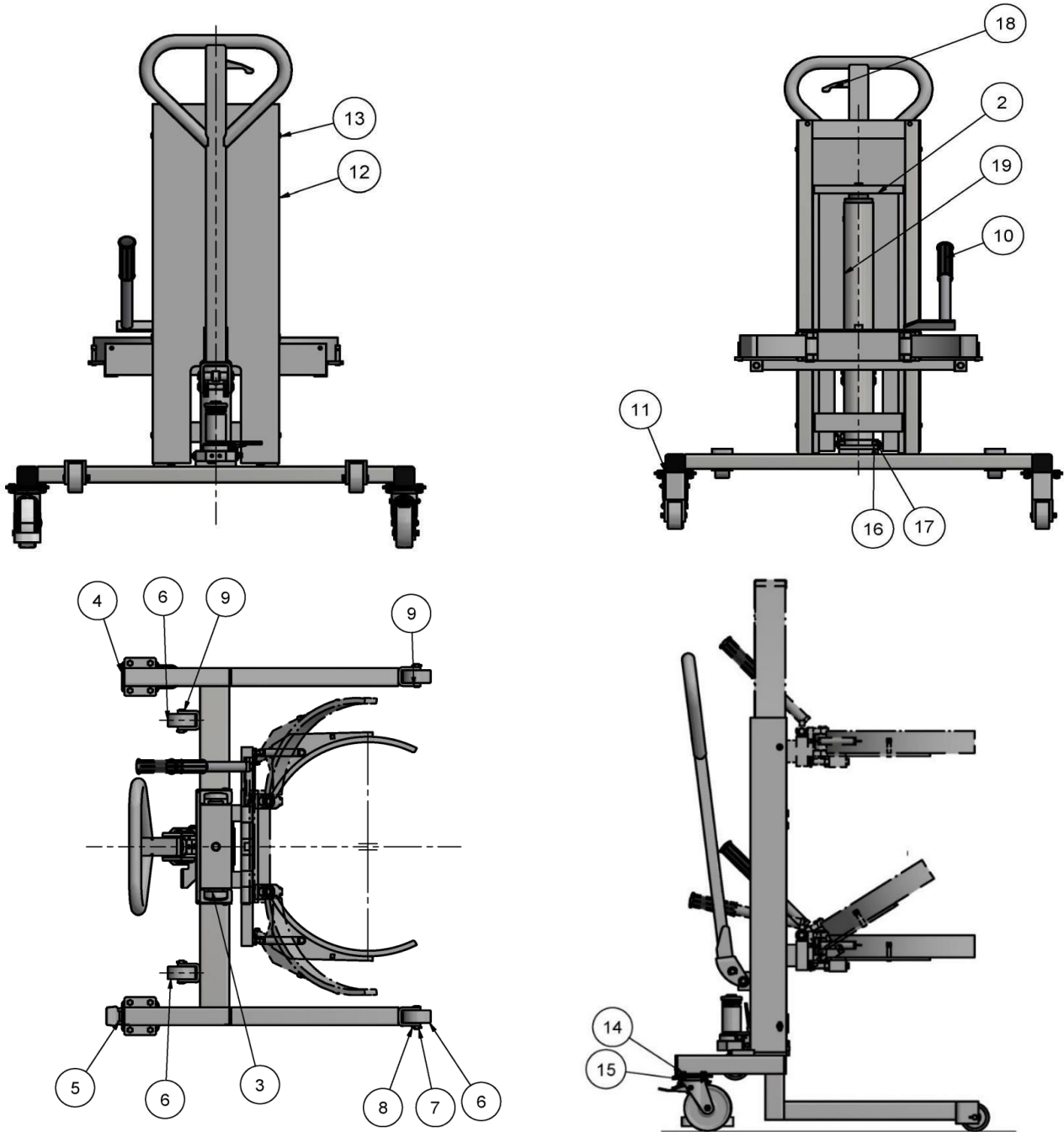

Complete Device:		Id.-Nr. GH17102447	
Pos.:	Order no.:	Parts name:	Quantity:
0001	GH 10 203 984	DRIVING DEVICE	1,000
0002	GH 11 610 718	LIFTING UNIT	1,000
0003	GH 13 600 177	GUIDE PULLEY	4,000
0004	GH 61 700 562	STEERING ROLLER	1,000
0005	GH 61 700 561	STEERING ROLLER	1,000
0006	GH 61 702 034	RUNNING WHEEL	4,000
0007	GH 00 004 143	AXLE	4,000
0008	GH 08 202 273	SPLIT	4,000
0009	GH 61 000 066	LOCK WASHER	4,000
0010	GH 61 500 510	GRIP COATING	1,000
0011	GH 61 500 548	SQUARE STOPPER	4,000
0012	GH 05 020 654	PROTECTION	1,000
0013	GH 60 700 700	COUNTERSUNK SCREW	4,000
0014	GH 60 500 155	HEXAGON SCREW	8,000
0015	GH 60 800 038	HEXAGON NUT	8,000
0016	GH 60 900 254	LOCK WASHER	4,000
0017	GH 60 500 328	SCREW SOCKET HEAD	4,000
0018	GH 18 301 099	DRAWBAR	1,000
0019	GH 66 200 400	LIFTING CYLINDER	1,000

13.2 Drum Clamp

Drawing

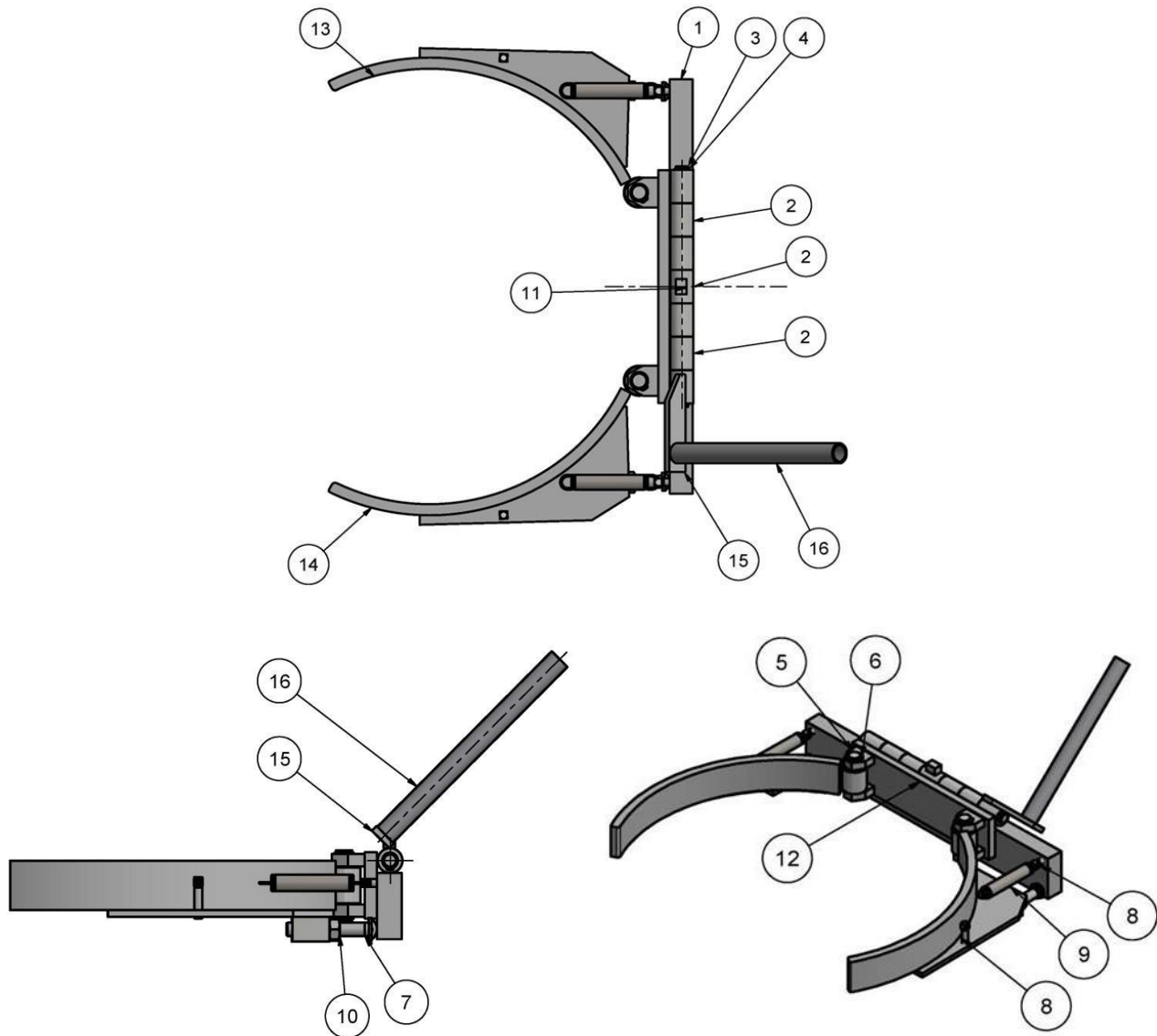

Drum Clamp:		Id.-Nr. GH10203988	
Pos.:	Order no.:	Parts name:	Quantity:
0001	GH 02 004 190	HOLDING PLATE	1,000
0002	GH 01 001 908	BUSHING	3,000
0003	GH 00 004 206	BEARING SHAFT	1,000
0004	GH 61 000 090	SEEGER RING	2,000
0005	GH 00 004 207	SHAFT	2,000
0006	GH 61 000 094	SEEGER RING	4,000
0007	GH 08 202 284	HEXAGON SCREW	2,000
0008	GH 08 202 285	SCREW	4,000
0009	GH 61 600 368	TENSION SPRING	2,000
0010	GH 60 800 048	HEXAGON NUT	2,000
0011	GHM0400013_0020	CUT OF RAW MATERIAL	1,000
0012	GH 10 203 987	JOINT PIECE	1,000
0013	GH 10 203 985	CLAMP	1,000
0014	GH 10 203 986	CLAMP	1,000
0015	GH 05 020 647	HOLDER	1,000
0016	GHM2400005_0300	TUBE	1,000

13.3 Guide Pulley

Drawing

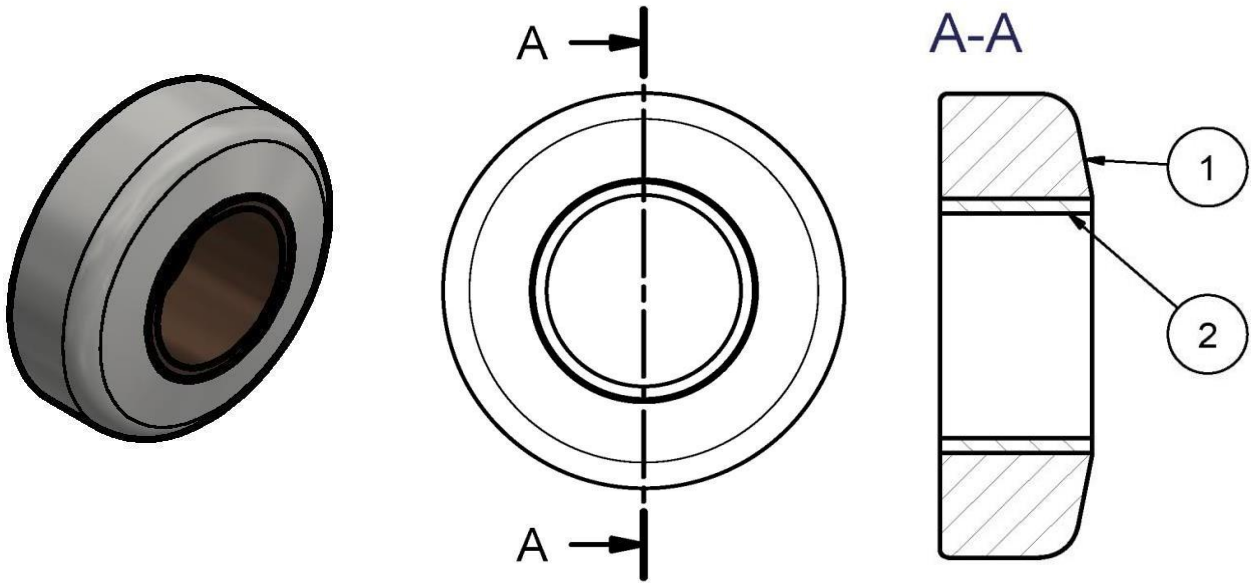

Guide Pulley:			Id.-Nr. GH13600177
Pos.:	Order no.:	Parts name:	Quantity:
0001	GH 07 800 202	GUIDE PULLEY	1,000
0002	GH 64 000 244	SLIDE BEARING	1,000

13.4 Lifting Cylinder

Drawing

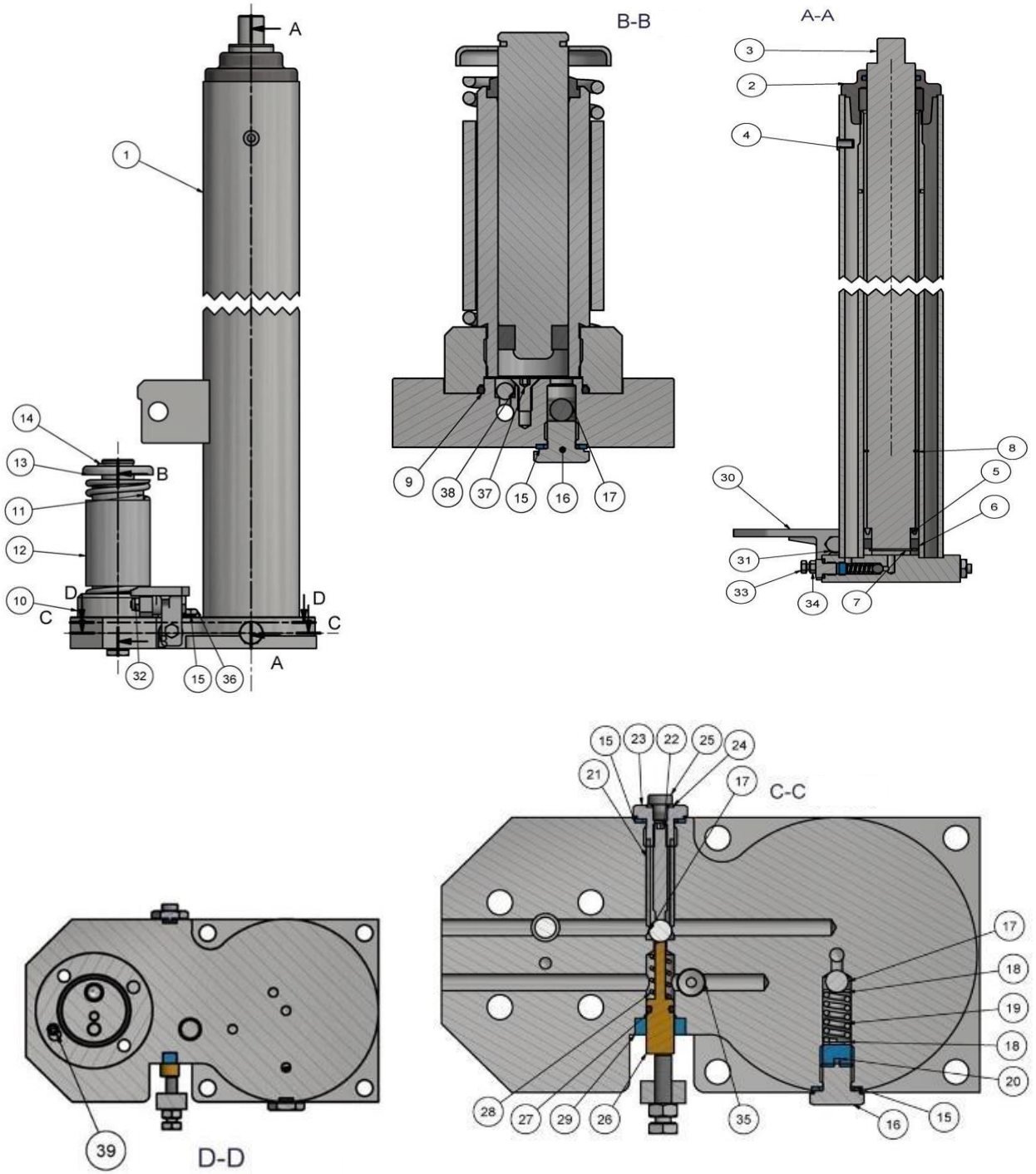

Lifting Cylinder:			Id.-Nr. GH66200400
Pos.:	Order no.:	Parts name:	Quantity:
0001	GH 11 401 033	HOUSING	1,000
0002	GH 11 400 642	COUPLING PIECE	1,000
0003	GH 07 000 425	PISTON	1,000
0004	GH 67 000 260	STOPPER	1,000
0005	GH 69 200 068	GROOVED RING	1,000
0006	GH 01 001 725	SLIDER	1,000
0007	GH 61 000 102	SEEGER RING	1,000
0008	GH 61 000 521	RING	1,000
0009	GH 68 500 160	RING O	1,000
0010	GH 01 001 759	ADAPTER	1,000
0011	GH 18 301 123	CYLINDER	1,000
0012	GH 61 600 339	PRESSURE SPRING	1,000
0013	GH 01 001 736	SPRING PLATE	1,000
0014	GH 61 000 195	SEEGER RING	1,000
0015	GH 68 900 078	RING	4,000
0016	GH 03 700 097	CLOSING SCREW	2,000
0017	GH 63 000 557	BALL	3,000
0018	GH 60 904 510	DISC	2,000
0019	GH 61 600 074	PRESSURE SPRING	1,000
0020	GH 60 600 140	THREADED PIN	1,000
0021	GH 61 600 072	PRESSURE SPRING	1,000
0022	GH 60 600 399	THREADED PIN	1,000
0023	GH 03 700 096	SETTING SCREW	1,000
0024	GH 68 900 048	RING USIT	1,000
0025	GH 60 500 426	SOCKET HEAD SCREW	1,000
0026	GH 00 003 761	PRESSURE BOLT	1,000
0027	GH 68 500 093	RING O	1,000
0028	GH 61 600 073	PRESSURE SPRING	1,000
0029	GH 69 500 220	ROTARY SHAFT SEAL	1,000
0030	GH 08 700 075	ANGLE LEVER	1,000
0031	GH 00 003 760	SCREW	1,000
0032	GH 60 800 102	HEXAGON NUT	1,000
0033	GH 60 500 141	HEXAGON SCREW	1,000
0034	GH 60 800 036	HEXAGON NUT	1,000
0035	GH 70 100 220	FILTER ELEMENT	1,000
0036	GH 03 700 094	CLOSING SCREW	1,000
0037	GH 60 500 844	COUNTERSUNK SCREW	1,000
0038	GH 63 000 550	BALL	1,000
0039	GH 68 500 159	RING O	1,000

13.5 Coupling Piece

Drawing

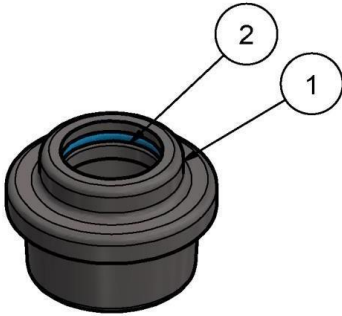

Coupling Piece:		Id.-Nr. GH11400642	
Pos.:	Order no.:	Parts name:	Quantity:
0001	GH 63 000 240	FONDERIE	1,000
0002	GH 68 500 255	RING O	1,000

13.6 Cylinder

Drawing

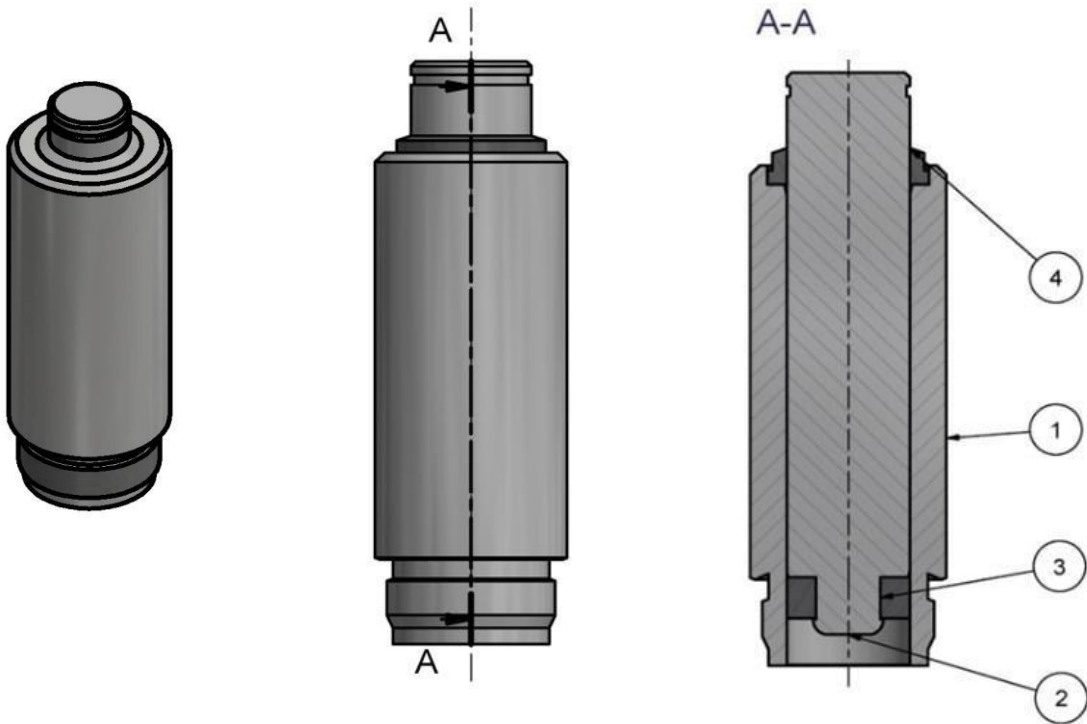

Cylinder:		Id.-Nr. GH18301123	
Pos.:	Order no.:	Parts name:	Quantity:
0001	GH 07 200 410	CYLINDER TUBE	1,000
0002	GH 07 000 421	PISTON ROD	1,000
0003	GH 69 200 070	GROOVED RING	1,000
0004	GH 69 000 201	SCRAPER RING	1,000

13.7 Ordering Spare Parts

Type:	FH 201
Capacity:	300 kg
Weight:	123 kg
Series-No.:	See type plate
Year of construction:	See type plate
VMH - Material Handling s.r.o. Sabinovská 53, 082 21 Veľký Šariš, SLOVAKIA Tel.: 00421 51 7495160 Fax.: 00421 51 7495160 E-mail: vmh@vmh.sk Web: www.vmh.sk	

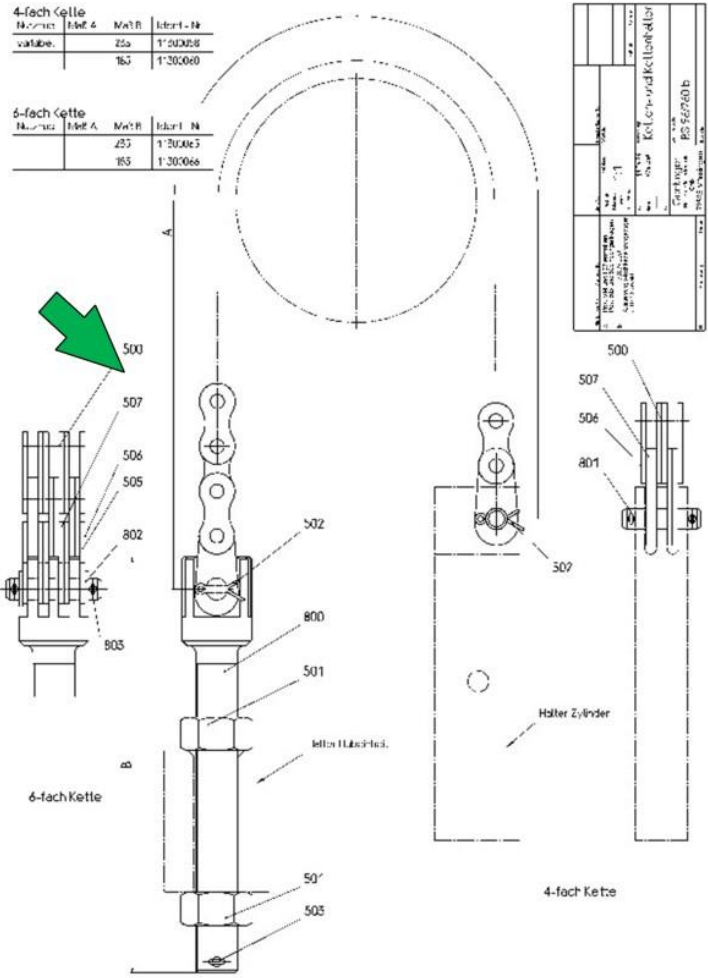

Customer Service Information	
VMH - Material Handling s.r.o. Sabinovská 53 082 21 Veľký Šariš Slovakia	00421 51 7495160
	00421 51 7495160
	vmh@vmh.sk
	www.vmh.sk

Chains and chain holders:			Id.-Nr.: 11300058
			Z.-Nr.: BS 96/260
Pos.	Order no.:	Parts name:	Quantity
500	61 800 077	CHAIN FLYER	1,00 MM
501	60 800 057	HEXAGON NUT	2,00 STK
502	60 900 401	SPLIT	4,00 STK
503	60 900 425	SPLIT	1,00 STK
506	61 800 078	CHAIN RIVET BOLTS	2,00 STK
507	61 800 091	CHAIN END PLATE	4,00 STK
507	61 800 090	CHAIN END PLATE	4,00 STK
801	00 000 158	BOLT	2,00 STK

	PLEASE NOTE!
<p> The following data must always be specified to ensure correct processing of your spare parts order: <ul style="list-style-type: none"> Serial no. as per type plate of the truck. Article no. of the spare part and its designation. The corresponding quantity of the spare part or the quantity required by you. </p>	

14 Annex: Bolting Torques

Dimension	Bolting torque					
	Nm	in.lbs	Nm	in.lbs	Nm	in.lbs
Property class	8.8		10.9		12.9	
M 4	2,8	25	4,1	36	4,8	42
M 5	5,5	49	8,1	72	9,5	84
M 6	9,6	85	14	124	16	141
M 8	23	204	34	301	40	354
M 10	46	407	67	593	79	699
M 12	79	699	115	1.017	135	1.195
M 14	125	1.106	185	1.637	220	1.947
M 16	195	1.725	290	2.566	340	3.008
M 18	280	2.477	400	3.539	470	4.159
M 20	395	3.495	560	4.955	660	5.840
M 22	540	4.778	760	6.725	890	7.875
M 24	680	6.017	970	8.583	1.150	10.175
M 27	1.000	8.848	1.450	12.830	1.700	15.042
M 30	1.350	11.945	1.950	17.254	2.300	20.350
M 8 x 1	25	221	37	327	43	380
M 10 x 1,25	49	434	71	628	83	734
M 12 x 1,25	87	770	130	1.150	150	1.327
M 12 x 1,5	83	734	120	1.062	145	1.283
M 14 x 1,5	135	1.195	200	1.770	235	2.079
M 16 x 1,5	210	1.858	310	2.743	360	3.185
M 18 x 1,5	315	2.787	450	3.982	530	4.690
M 20 x 1,5	440	3.893	557	4.630	730	6.459
M 22 x 1,5	590	5.220	840	7.432	980	8.671
M 24 x 2	740	6.547	1.050	9.290	1.250	11.060
M 27 x 2	1.100	9.733	1.550	13.714	1.800	15.926
M 30 x 2	1.500	13.272	2.150	19.023	2.500	22.120

Source: Bauer & Schaurte Kärcher GmbH, Abt. VFM
 Fatigue fracture: An introduction to modern screw calculation

15 Annex: Lubricant Table

The reliability and economy of our electrical trucks are dependent on quality of used lubricants. The under mentioned lubricants are approved.

Points of Lubrication				
Hydraulics • Foot pumps	Aral Vitam GF 22 Aral Vitam DE 22	BP Energol HLP-HM 22	Astron HLP 22 Actis HLPD 22	NUTO H 22 HLPD-OEL 22
• Electric pumps	Aral Vitam GF 46 Aral Vitam DE 46	BP Energol HLP-HM 46	Astron HLP 46 Actis HLPD 46	NUTO H 46 HLPD-OEL 46
Gears • Worm gears	Aral Degol BG 220 *Aral Getriebeöl EP SAE 85W-90	BP Energol GR-XP 220 *BP Energiegear Hypo 90 *BP Energiegear EP SAE 90	Falcon CLP 220 *Dearon EP-A SAE 85 W-90	SPARTAN EP 220 *ESSO GEAR OIL GP-D 85 W-90 *ESSO GEAR OIL GP 85 W-90
or • Spur gears	Aral Degol BG 100 *Aral Getriebeöl EP SAE 80W	BP Energol GR-XP 100 *BP Energiegear EP SAE 80 W	Falcon CLP 100 *Dearon EP-A SAE 80 W	SPARTAN EP 100 *ESSO GEAR OIL GP-D 80 W *ESSO GEAR OIL GP 80 W
Other oil lubricated Points	Aral Degol BG 100 *Aral Getriebeöl EP SAE 80 W	BP Energol GR-XP 100 *BP Energiegear EP SAE 80 W	Falcon CLP 100 *Dearon EP-A SAE 80 W	SPARTAN EP 100 *ESSO GEAR OIL GP-D 80 W *ESSO GEAR OIL GP 80 W
Grease lubricating point	*Aral Aralub HL 2 *Aral Mehrzweckfett	*BP Mehrzweckfett L 2 *BP Langzeitfett BP Energiegrease LS 2	Glissando 20 Dealit EP 2	BEACON 2 *EXXON MEHRZWECKFETT
Points of Lubrication				
Hydraulics • Foot pumps	*RENOLIN MR 5 VG 22 *RENOLIN B 5 VG 22	LAMORA HLP 32	Mobil DTE 22 Ultra	OEST Hydrauliköl H-LP 22 OEST Hydrauliköl 22 DD
• Electric pumps	*RENOLIN MR 15 VG 46 *RENOLIN B 15 VG 46	LAMORA HLP 46	Mobil DTE 25 Ultra Hydraulik Oil HLPD 46	OEST Hydrauliköl H-LP 46 OEST Hydrauliköl 46 DD
Gears • Worm gears	RENOLIN CLP 220 / PLUS RENOGEAR MP 90 RENOLIN CLP 150 / PLUS	Klüberoil GEM 1-220	*Mobilube GX 80W-90 Mobilgear 600 XP 220 Mobil SHC Gear 220	OEST Gearol C-LP 220 *OEST Mehrzweck- Getriebeöl SAE 85W-90
or • Spur gears	RENOGEAR MP 80	Klüberoil GEM 1-100	*Mobilube GX 85W-90-A Mobilgear 627	OEST Gearol C-LP 100 *OEST Mehrzweck- Getriebeöl SAE 80 W
Other oil lubricated Points	*RENOGEAR MP 80 RENOLIN CLP 100 / PLUS	Klüberoil GEM 1-100	*Mobilube GX 85W-90-A Mobilgear 600 XP 100	OEST Gearol C-LP 100 OEST Mehrzweck- Getriebeöl SAE 80 W
Grease lubricating point	RENOLIT MP RENOLIT LZR 2 RENOLIT FWA 160	CENTOPLEX 2	Mobilux EP 2 Mobilgrease XHP 222	*OEST Mehrzweckfett GOC 190 OEST Langzeitfett LT 200 EP
<p>*) Also available at petrol stations and authorised workshops These companies and their agencies maintain a technical service, whose advice on all lubrication problems is available free of charge.</p>				